

PETOL™ Drill Pipe Tong

DA6184

Operating Manual

GEARENCH™
P.O. Box 192
4450 South Highway 6
Clifton, Texas 76634
Phone: (254) 675-8651
Fax: (254) 675-6100

© 2018 by GEARENCH. All rights reserved

Form DA6184 revision 12-17-18

Table of Contents

DA6184 PETOL™ Drill Pipe Tong Description	1
Warranty	2
Overloading / Shock Loads / Side Loading	6
Environmental Conditions	7
Normal Life Expectancy	7
Lubrication	8
Periodic Inspection List for PETOL™ Special Chain	8
Operation	11
Suspension	11
Chain Screw Adjustment	12
Chain Identification Guide	13
Dimensions – clevis handles	14
Dimensions – loop handles	15
Torque and Diameter capacity	16
DA6184-C10 torque ratings and chain selection	16
DA6184-L21 torque ratings and chain selection	17
DA6184-L24 torque ratings and chain selection	18
DA6184-L36 torque ratings and chain selection	19
Parts List	20
Wear Limits	22
Non-Destructive Evaluation	23
Weld Repairs	24

DA6184 PETOL™ Drill Pipe Tong Description

The PETOL™ Drill Pipe Tongs were designed for making up and breaking out drill pipe, and tubular products. The DA6184 will work diameters from 4-1/4 inches to 10-3/4 inches and up to 37,300 foot-pounds of torque depending upon diameter and handle configuration.

The tongs are adjusted by exchanging chain sections and adjusting a chain screw nut to work the various diameters.

The Drill Pipe Tongs have the following features:

- A high strength, heat treated alloy chain for rugged, dependable service.

- High strength alloy steels used throughout for long life with the toughest jobs.

- A hanger attached to the tong handle to suspend the tong during operation when used on vertical pipe applications.

- A chain screw and nut to provide for fine adjustment of the chain.

- Loop and clevis handle ends in various lengths for most any application.

Warranty

What Is Covered

GEARENCH™ tools are expressly warranted to you, the purchaser, to be free of defects in material and workmanship.

How Long Coverage Lasts

This express warranty lasts for the lifetime of the GEARENCH tool. Warranty coverage ends when the tool becomes unusable for reasons other than defects in workmanship or material.

How Can You Get Warranty Service

To obtain the benefit of this warranty, contact a GEARENCH sales representative in Clifton, Texas.
GEARENCH · 4450 South Highway 6 · P.O. Box 192 · Clifton, TX 76634

What Will We Do To Correct Problems

Warranted products will be repaired or replaced, at GEARENCH's option, and returned at no charge to you, the original purchaser; or, if after three attempts at repair or replacement during the warranty period, the product defect in material or workmanship persists, you can elect to receive a full refund of your original purchase price for the product.

What Is Not Covered

Defects, failures or conditions that are due to normal wear and tear, abuse or misuse, are not covered by this limited warranty. In addition, this limited warranty is in lieu of all other warranties, express or implied, verbal or written. To the maximum extent allowed by law GEARENCH disclaims all implied warranties, including implied warranties of merchantability and/or fitness for a particular purpose. GEARENCH also specifically denies any liability for any incidental damages and/or consequential damages, including but not limited to property damage to property other than the product itself, loss of sales profits, down time, costs or any other damages measurable in money, whether or not included in the foregoing enumeration.

Please be advised that some states do not allow the exclusion or limitation of incidental or consequential damages, so this limitation or exclusion may not apply to you. This warranty gives you specific rights, and you may also have other rights, which vary from state to state, province to province, or country to country.

Are Personal Injuries Covered

In the event you, someone working for you, or any other person sustain a personal injury as a result of using the GEARENCH tool, GEARENCH limits its potential liability for such a claim or injury to the fullest extent allowed by law, and disclaims and denies any liability for such personal injury.

Please be advised that some states do not allow the exclusion or limitation of liability for personal injuries, so the above limitation or exclusion may not apply to you, or the individual claiming injury.

No Other Express Warranty Applies

This GEARENCH LIMITED WARRANTY is the sole and exclusive warranty, express or implied for GEARENCH products. No employee, agent, dealer or other person is authorized to alter, modify, expand or reduce the terms of this warranty or to make any other warranty on behalf of GEARENCH.

Law Applicable

All matters related to the sale and/or use of the GEARENCH tool that is the subject of this limited warranty, along with the construction and enforcement of the terms of this limited warranty itself, shall be subject to the substantive and procedural laws of the state of Texas, not the conflicts of laws provisions of Texas, but rather the laws of Texas themselves.

Forum Selection Clause

Any dispute arising out of the sale and/or use of the GEARENCH tool that is the subject of this limited warranty shall be presented in the form of a claim or lawsuit to the offices of GEARENCH in Clifton, Bosque County, Texas. No claim or suit may be brought against GEARENCH, arising out of the sale and/or use of the tool, or arising out of the terms of this warranty, except in such forum. Purchase and/or use of the GEARENCH tool makes you subject to the benefits and limitations of this limited warranty. Accordingly, any writ, judgment or other enforcement, obtained from a jurisdiction, county, parish, state or federal court or other country, other than that from the forum identified above, shall be void and unenforceable against GEARENCH.

Arbitration Clause

In the event of dispute or claim arises out of the sale and/or use of the GEARENCH tool that is the subject of this limited warranty, or arises out of the interpretation or enforcement of the terms and conditions of this limited warranty, such dispute shall be submitted to binding arbitration pursuant to the rules of the American Arbitration Association. If required to accomplish the purpose of this Arbitration clause, the purchaser hereby expressly waives any right to demand trial by jury.

Complete Agreement

This express limited warranty contains the entire agreement regarding express or implied warranties related to the GEARENCH tool that is the subject of it. No writing or language contained in the purchase order or any other document of the purchaser, or invoice of GEARENCH or any intermediate seller, shall be construed as modifying, in any way, the rights and liabilities contained in this limited warranty. GEARENCH expressly disclaims any obligations expressed in any customer purchase order or document that are contrary to the terms and limitations of this warranty.

Severability

If any term or limitation contained in this limited warranty is deemed unenforceable by law, then the term shall be severed from the remaining portions of the limited warranty which shall remain enforceable.

All communications to GEARENCH regarding the use of the tool and any aspect of the sale of the tool of this limited warranty should be addressed to GEARENCH.

GEARENCH · 4450 South Highway 6 · P.O. Box 192 · Clifton, TX 76634

Safe Practices and Procedures

Responsibility

"It is the responsibility of the employer to train the employee in the proper selection and usage of tools, chains, etc., and to ensure that they are selected and used in that manner. In many instances, injury results because it is assumed that anybody knows how to use common hand tools. Observations and the record show that this is not the case. A part of every job instruction program should therefore be detailed training in the proper use of hand tools (and of all other special tools and equipment needed to accomplish the job)." - (Source: National Safety Council)

"Employers are responsible for the safe condition of tools and equipment used by employees, including tools and equipment which may be furnished by employees." - (Source: OSHA 1910.242A)

Replacement Parts

Use only PETOL™ replacement parts - no other parts are of comparable strength, quality and interchangeability.

Safety

While we pride ourselves on the quality and dependability we build into GEARENCH™ tools and products, we caution users that it is only prudent to know and follow the simple rules of safety when using our products, or anyone else's.

Always follow safe practices and procedures in accordance with the recommendations of OSHA, The National Safety Council (NSC), The Hand Tools Institute (HTI), The National Association of Chain Manufacturers (NACM), The International Association of Drilling Contractors (IADC), Etc. All applicable Governmental rules, regulations or restrictions, now in effect or which may be promulgated, take precedence over the suggestions in this publication. The information in this publication is designed to supplement standard safe practices and procedures, not in lieu of, or replacement thereof.

Safe Practices

(Source: The National Safety Council)

Failure to observe one or more of the following five safe practices accounts for most hand and powered tool accidents:

1. ALWAYS WEAR SAFETY GOGGLES TO PROTECT EYES
2. SELECT THE RIGHT TOOL FOR THE JOB
3. KEEP TOOLS IN GOOD CONDITION
4. USE TOOLS CORRECTLY
5. KEEP TOOLS IN A SAFE PLACE

Safety Goggles must always be worn by persons in any area where hand and powered tools are being used.

Never apply excess leverage to a wrench or tool by means of a "Cheater Bar". Never strike wrenches and tools with hammers or other objects.

All tools should be kept clean, inspected on a regular basis, and replaced when they show signs of wear.

Be especially careful not to place yourself in a position that could result in bodily injury in the event of a failure. Brace yourself firmly and pull rather than push when wrenching. (If necessary to push, do so with the flat of the hand rather than gripping around the wrench.)

Never stand under or near loads being hoisted off the ground.

READ SAFE PRACTICES AND PROCEDURES MANUAL, CATALOG INFORMATION AND PRODUCT LABELING PRIOR TO OPERATION.

Spinning and drill pipe chain, cathead chain, and the PETOL™ Connecting Link attachment are designed for the specific purpose for which the name indicates. Chains and attachments that are to be used for any other purpose should be selected in accordance with the recommendations of ASTM, NACM, Rigger's Handbook, and the commercial chain manufacturer's technical manuals.

Safety Sources and Publications

In the interest of Safety the following sources of Safety information is furnished:

The Hand Tools Institute (HTI)
25 North Broadway
Tarrytown, New York 10591
(914) 332-0040
www.hti.org

The National Safety Council (NSC)
1121 Spring Lake Drive
Itasca, Illinois 60143-3201
(630) 285-1121
www.nsc.org

International Safety Council
1121 Spring Lake Drive
Itasca, Illinois 60143-3201
(630) 285-1121

Responsibility of Distributors

IT IS THE RESPONSIBILITY OF THE PURCHASERS OF GEARENCH PRODUCTS TO CONVEY THE INFORMATION IN THIS PUBLICATION AND ANY OTHER INFORMATION RELATING TO THE INDIVIDUAL PRODUCT, THROUGH THE CHANNELS OF DISTRIBUTION, DOWN TO AND INCLUDING THE INDIVIDUAL USING THE PRODUCT

NOTE:

In view of the fact that the actual use determines whether safety requirements have been met, the ultimate responsibility to comply rests with the end user.

The service life of leaf chains can be altered by a variety of adverse operating conditions. The following information discusses the most important of these conditions for consideration when operating or scheduling replacement of leaf chain systems.

Overloading / Shock Loads / Side Loading

Attempting to “inch loads which are beyond the rated capacity of the tool.

Striking the tool with a hammer or other object while force is being exerted in an attempt to loosen a “frozen” joint.

Side pull can be caused by pulling or pushing on the tong in a direction that is not along a perpendicular plane, unlevelled mounting of the tong or vise, inadequate support of the part being broken out, and improper seating of the part being broken out in the tong or vise. Improper seating will occur when the diameter of the part is not consistent within the width of the tong or vise jaw.

Environmental Conditions

Wrench chains operate in widely varying environments, from wet outdoor conditions to mildly or highly corrosive industrial atmospheres. They can also be exposed to abrasives such as sand or grit.

The possible effects include:

Moisture - Corrosion and rust reduce chain strength by causing pitting and cracking.

Temperature - Very cold temperatures reduce chain strength by embrittlement.

Chemical Solutions or Vapors - Corrosive attack of the chain components' grain structure and/or the mechanical connections between the chain components (crevice corrosion) may occur. Cracking often is microscopic. Propagation to complete failure can be eventual or sudden.

Abrasives - Accelerated wearing and scoring of the articulating chain members (pins and plates) may occur, with a corresponding reduction in chain strength. Due to inaccessibility of the bearing surfaces (pin surfaces and plate apertures), wear and scoring are not readily noticeable.

These conditions, when coupled with normal chain wear and inherent residual stress (normally in the chain as constructed), can result in environmentally assisted failure. It is impossible to predict chain life under complex conditions, as the degree of hostility and its effects are dependent on many variables such as temperature, time of exposure, concentration of corrosive atmosphere or medium, degree of abrasive wear, etc. Establishing the degree and frequency of unpredictable dynamic loading is also difficult.

Normal Life Expectancy

A leaf chain's normal life expectancy can be expressed as a maximum percent of elongation. This is generally between 2% and 3% of pitch. As the chain flexes back and forth, the bearing joints (pins and inside link plates) gradually wear from articulation. As with all steel bearing surfaces, the precision hardened steel joints of leaf chain require a constant film of oil between mating parts to prevent wear and to resist corrosion.

Lubrication



One of the most important but often-overlooked factors is adequate lubrication. In addition to reducing internal friction, maintaining a film of oil on all chain surfaces will inhibit rusting and corrosion. This is important as corrosion of highly stressed, hardened steel chain components can cause a major reduction in the load capacity of leaf chain and result in link plate cracking.

Protection from corrosion is important in storage as well as in service. The factory lubricant applied to PETOL™ Chain is a “Fingerprint Neutralizing Water-Displacing Corrosion Preventative”. This is an excellent rust and corrosion inhibitor for chains in storage. When installing these chains new, do not attempt to steam clean or degrease this lubricant. A grade of SAE 30 or 40 weight, non-detergent motor oil should be used as supplemental lubricant and a film of this oil should be maintained on all surfaces and internal bearing joints. Also, do not attempt to paint new chains. Though painting may help inhibit corrosion, it will seal off critical clearances and restricts oil from reaching the pin surfaces where it is needed for good joint lubrication.

When operating in dusty environments, lubricated chains will accumulate a paste-like buildup of grime. At periodic intervals, this buildup should be removed by cleaning and the chain should be immediately re-lubricated. Do not use caustic or acid type cleaners; use a stiff brush and a certified safe petroleum base solvent.

Periodic Inspection List for PETOL™ Special Chain

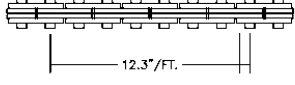
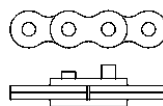
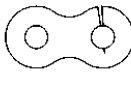
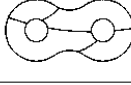
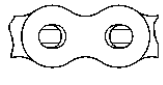
1. PRIOR TO EACH USE, LEAF CHAIN AND TOOLS SHOULD BE INSPECTED FOR SERVICEABILITY AND LUBRICATION.
2. USE ONLY PETOL™ AND TITAN™ REPLACEMENT PARTS - NO OTHER PARTS ARE OF COMPARABLE STRENGTH, QUALITY, AND INTERCHANGEABILITY.

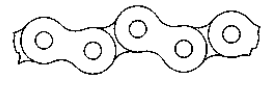
APPEARANCE AND/OR SYMPTOM	PROBABLE CAUSE	CORRECTION
<p>Excessive Length (Elongation)</p> 	<p>Normal wear</p> <p>Permanent deformation (stretch) from overload</p>	<p>Replace chain</p> <p>Replace chain and correct cause of overload</p>
<p>Abnormal Protrusion of Pins</p> 	<p>Overloading</p> <p>Inadequate lubrication</p> <p>Side loading</p>	<p>Replace chain and correct cause of overload</p> <p>Replace chain and improve lubrication</p> <p>Replace chain and correct cause of side load</p>
<p>Cracked Plates (Fatigue)</p> 	<p>Overloading</p> <p>Side loading</p>	<p>Replace chain and correct cause of overload</p> <p>Replace chain and correct cause of side load</p>
<p>Arc-Like Cracked Plates (Stress Corrosion)</p> 	<p>Severe rusting or exposure to acidic or caustic medium, plus static stress at press fit between pin and plate</p>	<p>Replace chain and protect from hostile environment</p>
<p>Enlarged Holes</p> 	<p>Overloading</p>	<p>Replace chain and correct cause of overload</p>
<p>Cracked Plates (Corrosion Fatigue) Perpendicular to Pitch Line, plus rust or other evidence of chemical corrosion</p> 	<p>Corrosive environment</p>	<p>Replace chain and protect from hostile environment</p>
<p>Fractured Plates (Tension Mode)</p> 	<p>Overloading</p>	<p>Replace chain and correct cause of overload</p>
<p>Tight Joints</p> 	<p>Dirt or foreign substance packed in joints</p> <p>Corrosion and rust</p> <p>Bent pins</p>	<p>Clean and relube</p> <p>Replace chain and protect from hostile environment</p> <p>Replace chain</p>

Safety Precautions

1. Always wear safety goggles to protect eyes.
2. Select the right tool for the job.
3. Keep tools in good condition.
4. Use tools correctly.
5. Keep tools in a safe place.
6. Wear protective clothing, gloves and safety shoes as appropriate.
7. Use lengths of assembled chain. Do not build lengths from individual components.
8. Do not attempt to rework damaged chain by replacing only the components obviously faulty. The entire chain may be compromised and should be discarded.
9. Never electroplate assembled leaf chains or components. Plating will result in failure from hydrogen embrittlement.
10. Do not weld any chain or component. Welding spatter should never be allowed to come into contact with chain or components.
11. Leaf chains are manufactured exclusively from heat-treated steels and therefore must not be annealed. If heating a chain with a cutting torch is absolutely necessary for removal, the chain should not be reused.
12. Inspect chains frequently and regularly for link plate cracking, pin turning, pin protrusion and corrosion.
13. Use only PETOL™ & TITAN™ replacement parts to ensure proper strength.

Operation

The typical application of one Drill Pipe Tong is shown in the figure below. Normally an additional tong is used as a backup. The backup tong is not shown for clarity. The tong will exert torque when the cylinder is retracted as shown. The tong will ratchet when the cylinder is extended. Ratcheting is used when the tong must be pulled more than once to completely makeup or breakout the connection.

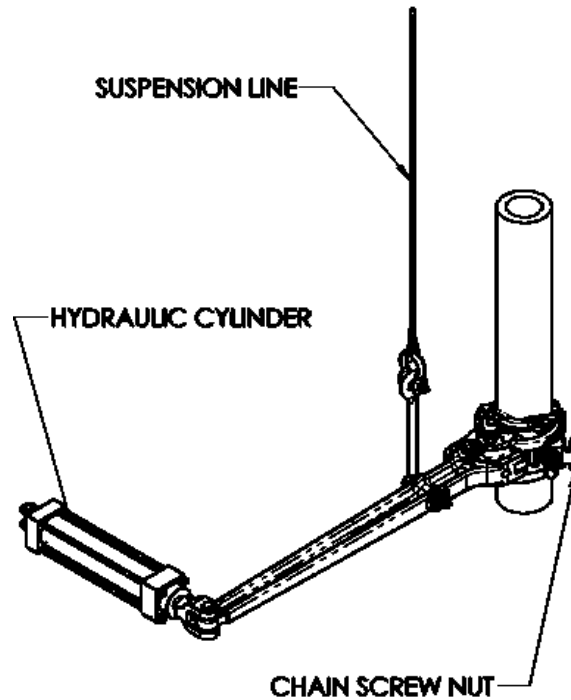

Suspension

When working vertical pipe, the tong should be suspended by the attached hanger. Adjust the hanger to obtain the best possible balance of the tong. Always use a suspension line of adequate capacity to safely hold up the tong during operation.

Chain Screw Adjustment

Adjust the chain screw nut for approximately 1/2" clearance between the lower handle bumper and the contact surface on the jaw as shown in the diagram below. The jaw spring must be compressed to latch the chain screw nut.

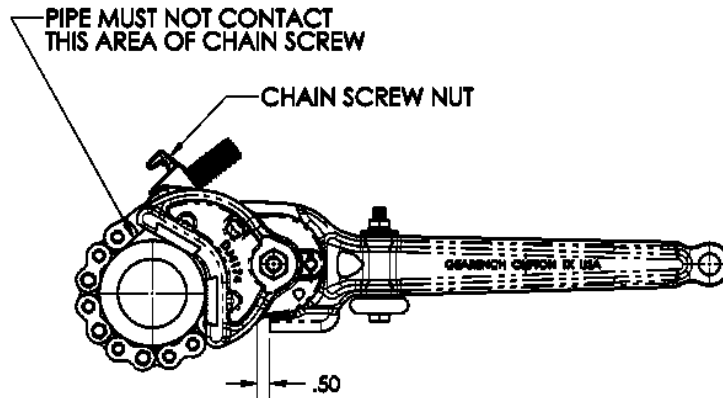

Warning! The pipe must NOT contact the side of the chain screw as shown above. Contact will cause premature breakage of the chain screw and could cause injury or death. If the chain screw contacts the pipe, the chain MUST be lengthened by adding 2 pitches of chain.

Chain Identification Guide

2 LINK SECTION

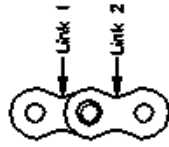

5 LINK SECTION

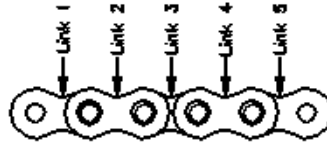

CHAIN ASSEMBLY

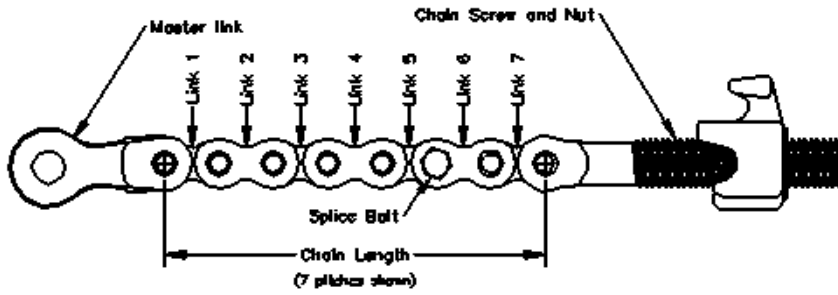

THIS IS WHAT A CHAIN PART NUMBER TELLS YOU

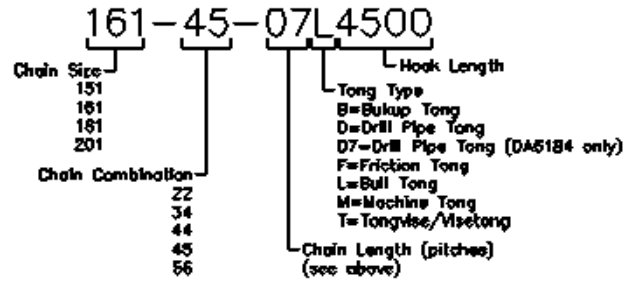

Dimensions – clevis handles

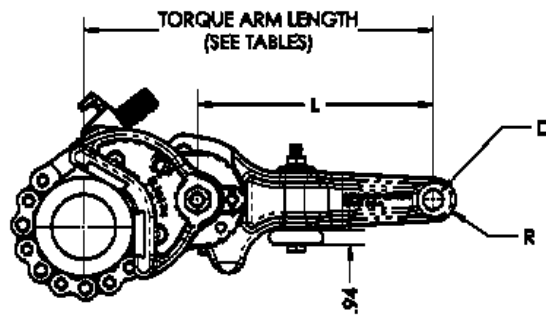
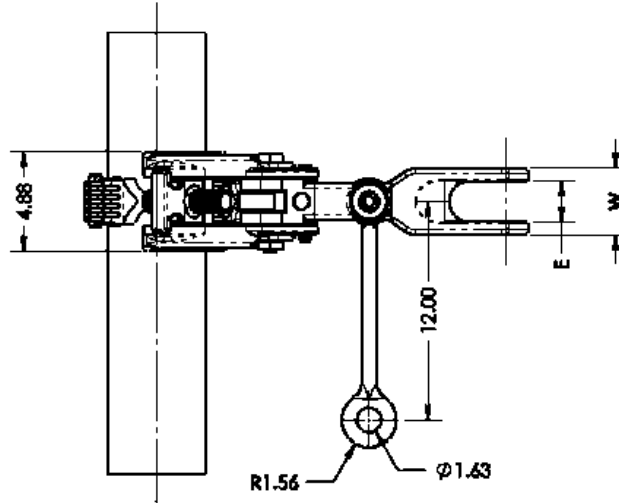

Assembly	L	D	R	E	W
DA6184-C10	10.00	1.005	1.06	2.06	3.44

Dimensions – loop handles

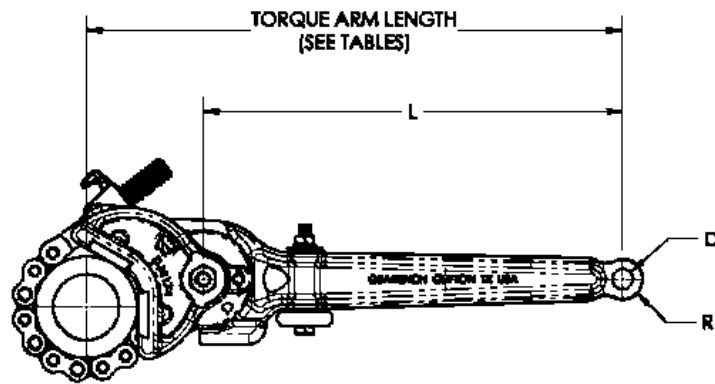
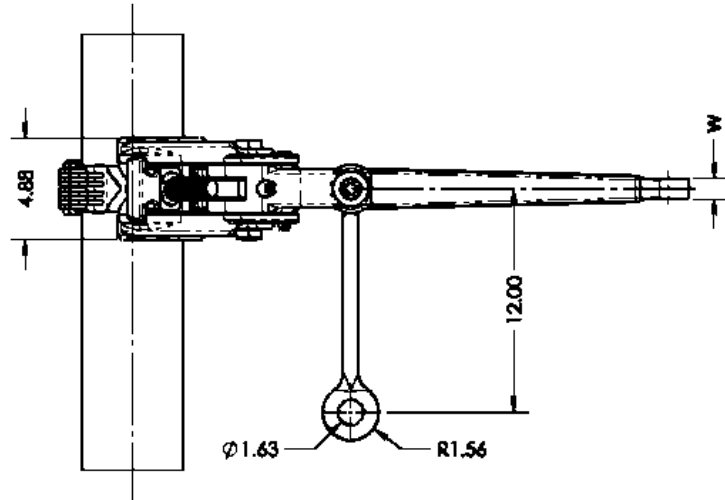

Assembly	L	D	R	W
DA6184-L21	21.00	1.005	1.13	1.00
DA6184-L24	24.00	1.005	1.13	1.00
DA6184-L36	35.88	1.005	1.13	1.00

Torque and Diameter capacity

The following table lists the maximum working torques and the corresponding handle loads for the diameter range of the assembly. The table used must match the handle and pipe used in the assembly. Torque arm lengths, maximum torque and maximum handle load will vary with each diameter and handle combination.

DA6184-C10 torque ratings and chain selection				
Diameter	Torque Arm Length (inches)	Maximum Torque (foot-pounds)	Maximum Handle Load (pounds)	Chain Number
4-1/4	16.75	26,500	19,000	151-45-09D7 (4-1/4 - 4-3/4)
4-1/2	16.88	26,500	18,800	
4-3/4	17.00	27,600	19,500	
5	17.13	28,600	20,000	151-45-11D7 (4-3/4 – 5-3/4)
5-1/4	17.25	29,200	20,300	
5-1/2	17.38	30,200	20,900	
5-3/4	17.50	31,600	21,700	
6	17.63	32,500	22,100	151-45-13D7 (5-3/4 – 6-5/8)
6-1/4	17.75	32,900	22,300	
6-1/2	17.88	32,900	22,300	
6-3/4	18.00	33,400	22,300	151-45-15D7 (6-5/8 – 7-1/2)
7	18.13	33,400	22,300	
7-1/4	18.25	33,900	22,300	
7-1/2	18.38	33,900	22,300	
7-3/4	18.50	34,400	22,300	151-45-17D7 (7-1/2 – 8-1/4)
8	18.63	34,400	22,300	
8-1/4	18.75	34,900	22,400	
8-1/2	18.88	34,900	22,400	151-45-19D7 (8-1/4 – 9)
8-3/4	19.00	35,400	22,400	
9	19.13	35,400	22,400	
9-1/4	19.25	35,800	22,400	151-45-21D7 (9 – 9-7/8)
9-1/2	19.38	35,800	22,400	
9-3/4	19.5	36,300	22,400	
10	19.63	36,300	22,400	151-45-23D7 (9-7/8 – 10-3/4)
10-1/4	19.75	36,800	22,400	
10-1/2	19.88	36,800	22,400	
10-3/4	20.00	37,300	22,400	

WARNING: Under no circumstances should the maximum working load be exceeded. Overloading may result in injury or death. Always use a load cell or other calibrated indicating device to monitor the line pull on the tong to avoid an overload.

DA6184-L21 torque ratings and chain selection				
Diameter	Torque Arm Length (inches)	Maximum Torque (foot-pounds)	Maximum Handle Load (pounds)	Chain Number
4-1/4	37.38	23,700	10,400	151-45-09D7 (4-1/4 - 4-3/4)
4-1/2	27.50	24,800	10,800	
4-3/4	27.63	25,800	11,200	
5	27.75	26,600	11,500	151-45-11D7 (4-3/4 – 5-3/4)
5-1/4	27.88	26,700	11,500	
5-1/2	28.00	26,800	11,500	
5-3/4	28.13	27,000	11,500	
6	28.25	27,100	11,500	151-45-13D7 (5-3/4 – 6-5/8)
6-1/4	28.38	27,200	11,500	
6-1/2	28.50	27,300	11,500	
6-3/4	28.63	27,400	11,500	151-45-15D7 (6-5/8 – 7-1/2)
7	28.75	27,600	11,500	
7-1/4	28.88	27,700	11,500	
7-1/2	29.00	27,800	11,500	
7-3/4	29.13	27,900	11,500	151-45-17D7 (7-1/2 – 8-1/4)
8	29.25	28,000	11,500	
8-1/4	29.38	28,200	11,500	
8-1/2	29.50	28,300	11,500	151-45-19D7 (8-1/4 – 9)
8-3/4	29.63	28,400	11,500	
9	29.75	28,500	11,500	
9-1/4	29.88	28,600	11,500	151-45-21D7 (9 – 9-7/8)
9-1/2	30.00	28,800	11,500	
9-3/4	30.13	28,900	11,500	
10	30.25	29,000	11,500	151-45-23D7 (9-7/8 – 10-3/4)
10-1/4	30.38	29,100	11,500	
10-1/2	30.50	29,200	11,500	
10-3/4	30.63	29,300	11,500	

WARNING: Under no circumstances should the maximum working load be exceeded. Overloading may result in injury or death. Always use a load cell or other calibrated indicating device to monitor the line pull on the tong to avoid an overload.

DA6184-L24 torque ratings and chain selection				
Diameter	Torque Arm Length (inches)	Maximum Torque (foot-pounds)	Maximum Handle Load (pounds)	Chain Number
4-1/4	30.38	23,500	9,300	151-45-09D7 (4-1/4 - 4-3/4)
4-1/2	30.50	24,500	9,700	
4-3/4	30.63	25,500	10,000	
5	30.75	25,800	10,100	151-45-11D7 (4-3/4 – 5-3/4)
5-1/4	30.88	25,900	10,100	
5-1/2	31.00	26,000	10,100	
5-3/4	31.13	26,100	10,100	
6	31.25	26,200	10,100	151-45-13D7 (5-3/4 – 6-5/8)
6-1/4	31.38	26,300	10,100	
6-1/2	31.50	26,400	10,100	
6-3/4	31.63	26,500	10,100	151-45-15D7 (6-5/8 – 7-1/2)
7	31.75	26,600	10,100	
7-1/4	31.88	26,700	10,100	
7-1/2	32.00	26,800	10,100	
7-3/4	32.13	26,900	10,100	151-45-17D7 (7-1/2 – 8-1/4)
8	32.25	27,000	10,100	
8-1/4	32.38	27,200	10,100	
8-1/2	32.50	27,300	10,100	151-45-19D7 (8-1/4 – 9)
8-3/4	32.63	27,400	10,100	
9	32.75	27,500	10,100	
9-1/4	32.88	27,600	10,100	151-45-21D7 (9 – 9-7/8)
9-1/2	33.00	27,700	10,100	
9-3/4	33.13	27,800	10,100	
10	33.25	27,900	10,100	151-45-23D7 (9-7/8 – 10-3/4)
10-1/4	33.38	28,000	10,100	
10-1/2	33.50	28,100	10,100	
10-3/4	33.63	28,200	10,100	

WARNING: Under no circumstances should the maximum working load be exceeded. Overloading may result in injury or death. Always use a load cell or other calibrated indicating device to monitor the line pull on the tong to avoid an overload.

DA6184-L36 torque ratings and chain selection				
Diameter	Torque Arm Length (inches)	Maximum Torque (foot-pounds)	Maximum Handle Load (pounds)	Chain Number
4-1/4	42.25	23,700	6,700	151-45-09D7 (4-1/4 - 4-3/4)
4-1/2	42.38	23,700	6,700	
4-3/4	42.50	23,700	6,700	
5	42.63	23,700	6,700	151-45-11D7 (4-3/4 – 5-3/4)
5-1/4	42.75	23,700	6,700	
5-1/2	42.88	24,000	6,700	
5-3/4	43.00	24,000	6,700	
6	43.13	24,000	6,700	151-45-13D7 (5-3/4 – 6-5/8)
6-1/4	43.25	24,000	6,700	
6-1/2	43.38	24,300	6,700	
6-3/4	43.50	24,300	6,700	151-45-15D7 (6-5/8 – 7-1/2)
7	43.63	24,300	6,700	
7-1/4	43.75	24,300	6,700	
7-1/2	43.88	24,600	6,700	
7-3/4	44.00	24,600	6,700	151-45-17D7 (7-1/2 – 8-1/4)
8	44.13	24,600	6,700	
8-1/4	44.25	24,600	6,700	
8-1/2	44.38	24,900	6,700	151-45-19D7 (8-1/4 – 9)
8-3/4	44.50	24,900	6,700	
9	44.63	24,900	6,700	
9-1/4	44.75	24,900	6,700	151-45-21D7 (9 – 9-7/8)
9-1/2	44.88	25,100	6,700	
9-3/4	45.00	25,100	6,700	
10	45.13	25,100	6,700	151-45-23D7 (9-7/8 – 10-3/4)
10-1/4	45.25	25,100	6,700	
10-1/2	45.38	25,400	6,700	
10-3/4	45.50	25,400	6,700	

WARNING: Under no circumstances should the maximum working load be exceeded. Overloading may result in injury or death. Always use a load cell or other calibrated indicating device to monitor the line pull on the tong to avoid an overload.

Parts List

The following drawings, diagrams, and parts lists describe all parts, which may be needed as replacement items.

All tong components are manufactured only by GEARENCH™. DO NOT ATTEMPT TO SUBSTITUTE THESE COMPONENTS. The tong will not work properly unless these components are matched to the specific application. Consult our factory as your requirements change. Any non-GEARENCH substitutions of these components void all warranties and subject the user to assumption of liabilities resulting from subsequent use.

Tong Assembly Parts List

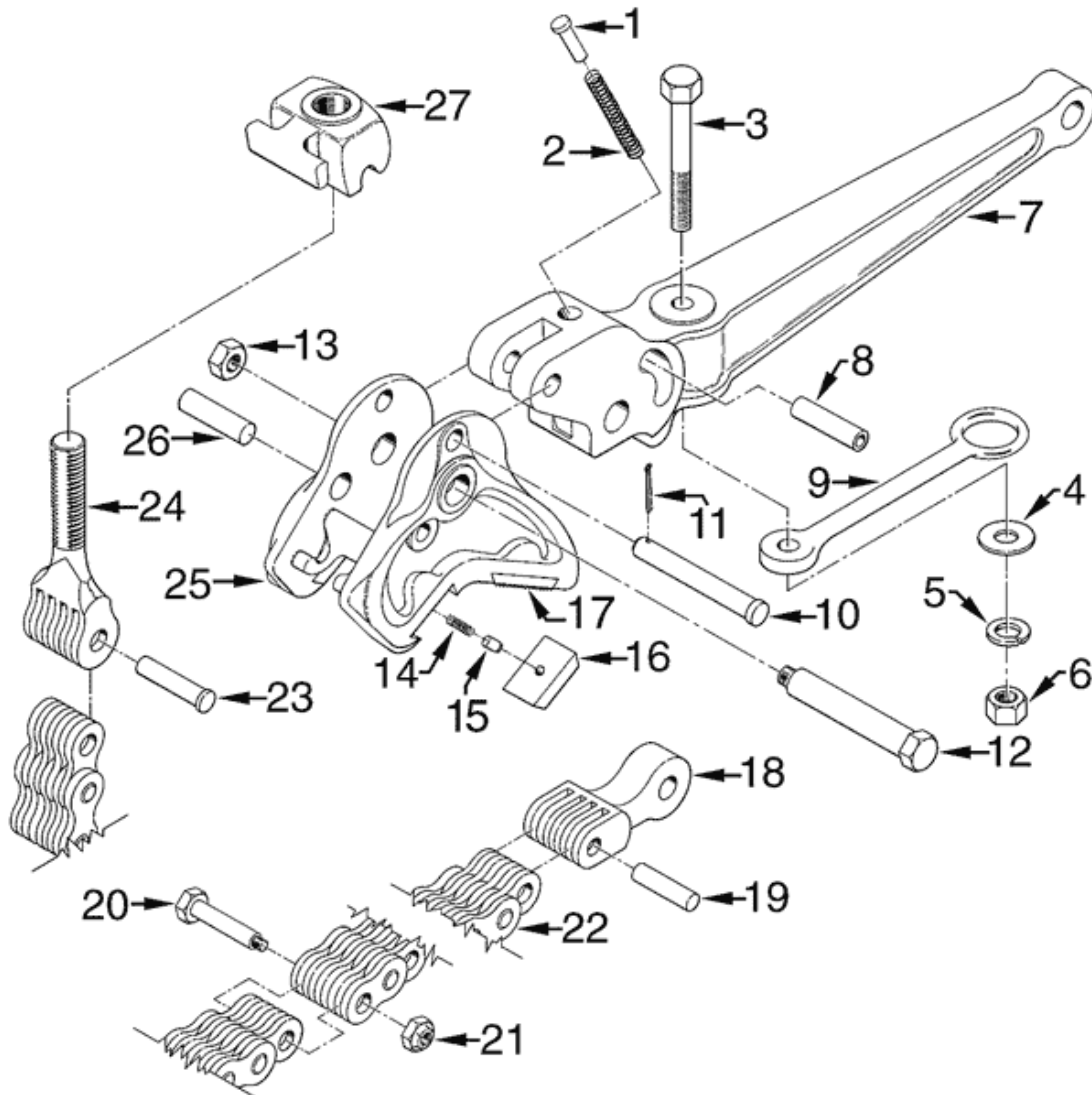

Note: 4 diamond point or 4 knurled inserts are required to grip 4-1/2 – 4-3/4 diameters. Do not use blank inserts (item 16) with these diameters.

Tong Assembly Parts List

Item	Qty.	Part Number	Description
1	1	HG10	Spring guide
2	1	HS27	Spring
3	1	HB17	Hanger bolt
4	1	HXW001	Hanger flat washer
5	1	HXW002	Hanger lock washer
6	1	HXN023	Hanger nut
7	1	DH6184-C10	Handle, 10" clevis
7	1	DH6184-L21	Handle, 21" loop
7	1	DH6184-L24	Handle, 24" loop
7	1	DH6184-L36	Handle, 36" loop
8	1	HU40	Spring pin bushing
9	1	HH16	Bar hanger
10	1	HP238	Spring pin
11	1	HXC002	Spring pin cotter
12	1	HB35	Jaw bolt
13	1	HXN003	Jaw bolt nut
14	4	HS20S	Insert key spring
15	4	HP903	Insert key
16	2	HI04B	Blank insert (see note above)
17	2	HI04D	Diamond point insert (standard)
17	2	HI04D-M2	Diamond point insert (optional AISI M2)
17	2	HI04K	Knurled insert (optional)
17	2	HI04K-M2	Knurled insert (optional AISI M2)
18	1	HM01-45	Master link
19	1	HP237	Master link - chain rivet
20	As req'd	HB48	Chain splice bolt
21	As req'd	HXN015	Chain splice bolt nut
22	As req'd	151-45-02	Special chain link (2 link section)
22	As req'd	151-45-04	Special chain link (4 link section)
22	As req'd	151-45-07	Special chain link (7 link section)
22	As req'd	151-45-06	Special chain link (6 link section)
23	As req'd	HP236	Chain screw rivet
24	1	HV02-45	Chain screw
25	1	DJ6184	Jaw
26	1	HP235	Master link – handle pin
27	1	HN01	Chain screw nut

Wear Limits

The following table indicates limiting diameters on the components of the PETOL™ Drill Pipe Tong. When localized wear is beyond any one of the limits indicated, the component should be replaced.

Part Number	Description	Location	Limit Dimension
HB35	Jaw – handle bolt	Pin body diameter	0.980 (min)
HP235	Master link – handle pin	Pin body diameter	0.734 (min)
HB48	Chain splice bolts	Bolt body diameter	0.427 (min)
151-45-XX	Chain links	Pin hole diameter	0.451 (max)
151-45-XX	Chain links	Pitch center – center	1.287 (max per pitch)
DH6184-XXX	Handle	Jaw pin hole diameter	1.025 (max)
DH6184-XXX	Handle	Chain pin hole diameter (master link)	0.769 (max)
DH6184-XXX	Handle	Load loop diameter	1.031 (max)
DJ6184	Jaw	Jaw pin hole diameter	1.025 (max)
HM01-45	Master link	Handle pin diameter	0.769 (max)
HM01-45	Master link	Chain pin diameter	0.451 (max)
HV02-45	Chain screw	Chain pin diameter	0.451 (max)

Non-Destructive Evaluation

The figures below indicate the critical areas of the tong handle and jaw. A critical area is defined as an area in which no unrepaired crack indications are permitted and in which no major weld repairs are permitted. There are no critical areas on the bar hanger. Weld repairs are only permitted on the handle, jaw, and bar hanger.

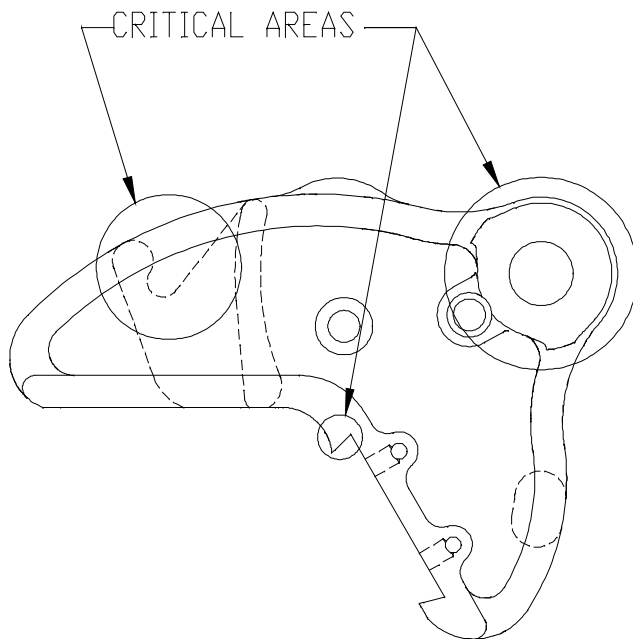
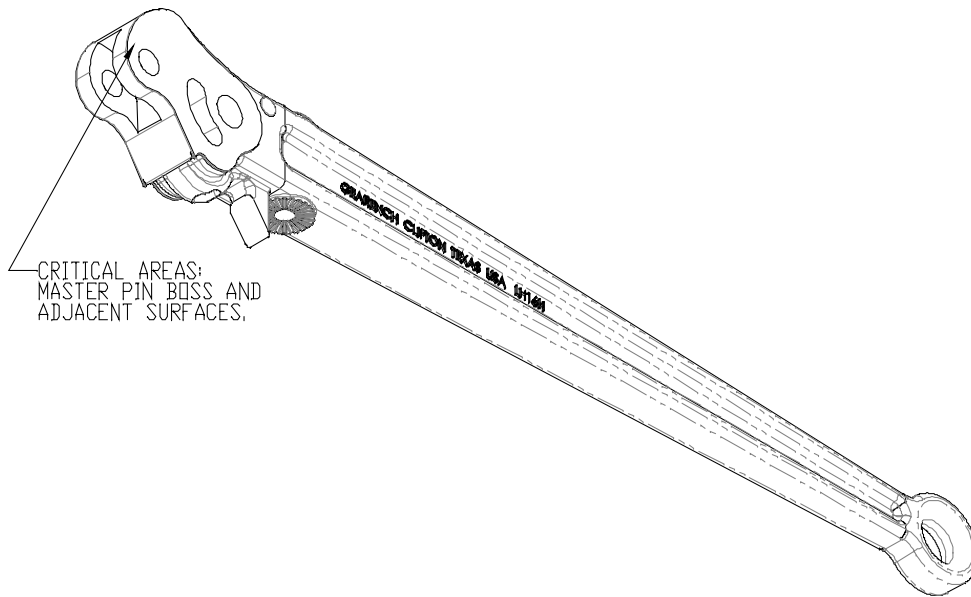

Weld Repairs

Scope:

This procedure is to be followed for minor repairs of crack indications in heat treated alloy steels. A weld repair shall be considered minor when the depth of the cavity does not exceed 30% of the actual wall thickness or 1 inch, whichever is smaller, or when the extent of the cavity does not exceed approximately 10 square inches. Major weld repairs must be performed by GEARENCH™ or an approved repair center using appropriate procedures followed by full heat treatment and load testing.

Application:

This procedure applies to steel castings, forgings and, wrought with carbon content between 0.15% and 0.31%.

Weld preparation:

The crack indication is to be removed by carbon arc gouging, grinding, or machining until all indication is removed. Magnetic particle inspection shall be used to verify that the crack indication has been removed.

Filler material and process:

Repairs made with the FCAW process shall use a filler material of class E120T5-K4 or equivalent with CO₂ shielding gas. Repairs made with the SMAW process shall use a filler material of type E-12018-M. All welding is to be performed by a qualified welder.

Preheat:

Preheat the weld area to 300°F minimum.

Interpass temperature:

The interpass temperature is to be 600°F maximum. All weld slag to be removed prior to application of additional layers by chipping, grinding or wire brushing. Do not peen the weld repair.

Post weld heat treatment:

Do not allow weld to cool below 300°F before stress relief. Post heat immediately after welding to 1010 - 1040°F for 1 hour per inch of thickness, 2 hours minimum at temperature. Water quench after stress relief.

Weld blending and inspection:

The weld is to be ground flush with the adjacent parent material. The weld is to be inspected by magnetic particle to verify that the weld area is free of all crack indications.