

PETOL[®] HYDRA-TORK[®]

U115H / U115H-S

Operating Manual

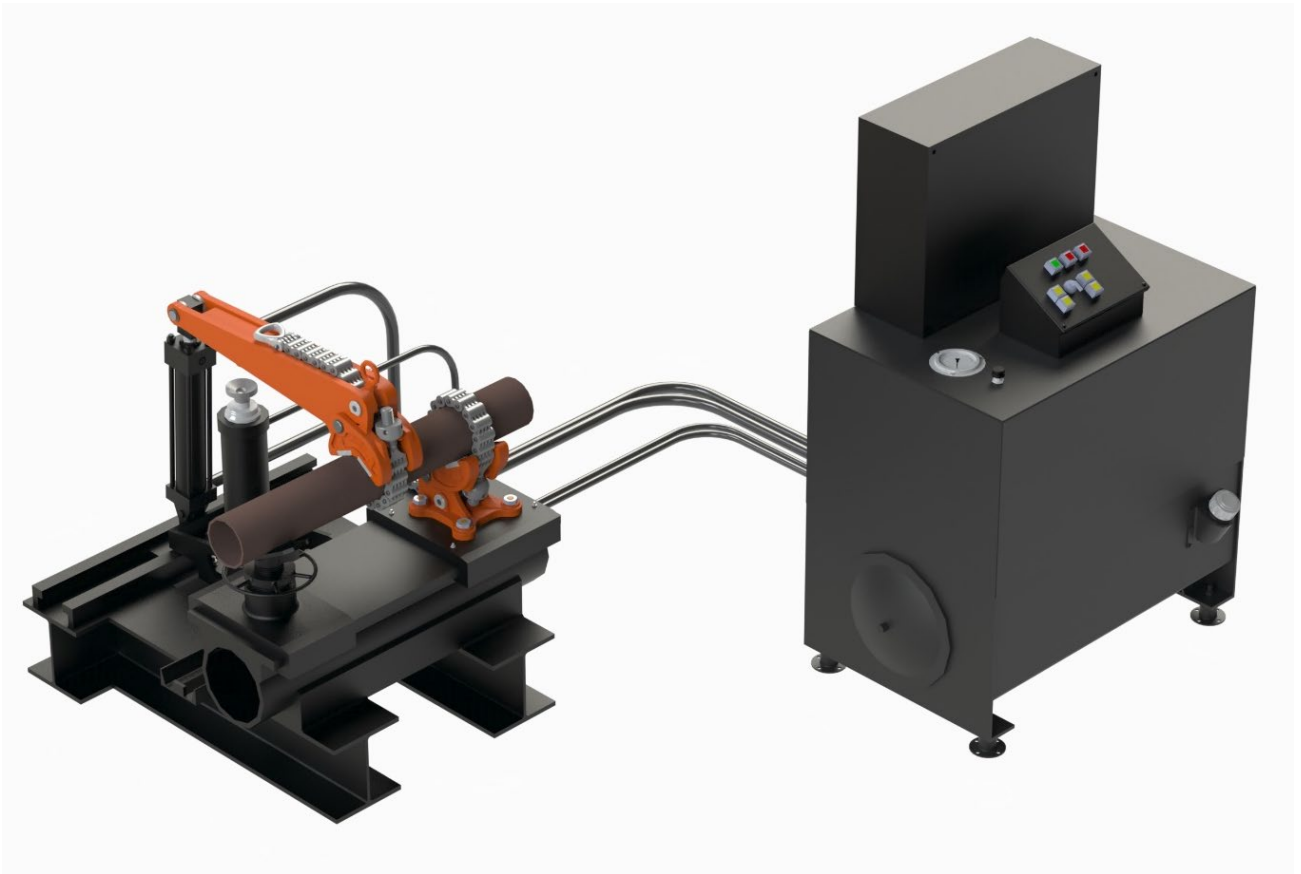

4450 S. Hwy. 6 | P.O. Box 192
Clifton, TX 76634 | USA
www.PETOL.com

sales@petol.com | 254.675.8651

© 2025 by PETOL[®]. All rights reserved.

Form U115H revision 03/24/2025

Table of Contents

PETOL® U115H HYDRA-TORK® Description	1
Part number description.....	1
Warranty	2
Safe Practices and Procedures.....	4
Responsibility	4
Replacement Parts	4
Safety.....	4
Safe Practices	4
Safety Sources and Publications.....	5
Responsibility of Distributors.....	5
Overloading / Shock Loads / Side Loading.....	6
Environmental Conditions.....	6
Normal Life Expectancy.....	6
Lubrication	7
Periodic Inspection List for PETOL® Special Chain.....	8
Safety Precautions	9
Installation.....	10
Location.....	10
Setup.....	10
Electrical Wiring	10
Startup	10
Operation.....	11
Controls.....	11
TORQUE-PRESSURE CONVERSION.....	13
Hydraulic Console.....	14
Control Panel.....	15
Loading.....	16
Vise and Tong Adjustment.....	16
Breaking Out.....	16
Making Up.....	17
Calibration.....	17
Recommended Calibration Points	18
Parts List.....	19
Final Assembly Dimensions and Parts List (standard base).....	19
Final Assembly Dimensions and Parts List (skid mount).....	20
Console Assembly Parts List.....	22
Hydraulic Schematic	23
Control Panel Parts List.....	25
Main Electrical Panel Parts List	26
Cylinder Assembly Parts List.....	28
Cylinder Carriage Parts List	29
Vee Saddle Assembly Parts List.....	31
Vise Assembly Parts List.....	32
Tong Assembly Parts List.....	33
PETOL® Special Chain Parts List	34
Electrical Schematic	35

PETOL® U115H HYDRA-TORK® Description

The U115H PETOL® HYDRA-TORK® unit was designed for making up and breaking out downhole tools. It is rated for operation on 2" to 8" diameters with a maximum working load of 14,000 ft-lbs.

The PETOL Pulldown Visetong and PETOL Tongvise are adjusted to the different ODs within their range by pulling the PETOL Special Chain through the jaw and engaging a cam lock lever. No addition or removal of chain sections is required.

The U115H also offers the following features:

A shock mounted hydraulic console not attached to the base to provide maximum flexibility in the setup and location of the power unit for efficient use of space. All controls are 24 volts AC, NEMA type 13.

The tong cylinder and vise base are mounted on tracks for switching from make up to break out.

One adjustable vee-saddle mounted on the HYDRA-TORK base for added support. This vee-saddle is also mounted on tracks for easy adjustment.

Optional automatic cycling of the tong for long make-up and breakout jobs.

Optional digital torque display for direct reading of torque in 100 foot-pound increments with an auxiliary output for data logging at 1 volt / 5,000 foot-pounds.

Operating voltages are 190/208/230/380/460 volts, 3 phase, 5 horsepower. Other voltages are available upon request.

Part number description

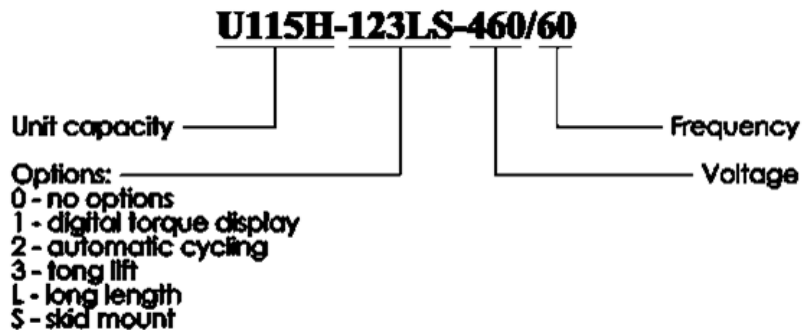

Warranty

What Is Covered

PETOL® tools are expressly warranted to you, the purchaser, to be free of defects in material and workmanship.

How Long Coverage Lasts

This express warranty lasts for the lifetime of the PETOL tool. Warranty coverage ends when the tool becomes unusable for reasons other than defects in workmanship or material.

How Can You Get Warranty Service

To obtain the benefit of this warranty, contact a PETOL sales representative in Clifton, Texas.

PETOL · 4450 S. Highway 6 · P.O. Box 192 · Clifton, TX 76634

What Will We Do To Correct Problems

Warranted products will be repaired or replaced, at PETOL's option, and returned at no charge to you, the original purchaser; or, if after three attempts at repair or replacement during the warranty period, the product defect in material or workmanship persists, you can elect to receive a full refund of your original purchase price for the product.

What Is Not Covered

Defects, failures or conditions that are due to normal wear and tear, abuse or misuse, are not covered by this limited warranty. In addition, this limited warranty is in lieu of all other warranties, express or implied, verbal or written. To the maximum extent allowed by law PETOL disclaims all implied warranties, including implied warranties of merchantability and/or fitness for a particular purpose. PETOL also specifically denies any liability for any incidental damages and/or consequential damages, including but not limited to property damage to property other than the product itself, loss of sales profits, down time, costs or any other damages measurable in money, whether or not included in the foregoing enumeration.

Please be advised that some states do not allow the exclusion or limitation of incidental or consequential damages, so this limitation or exclusion may not apply to you. This warranty gives you specific rights, and you may also have other rights, which vary from state to state, province to province, or country to country.

Are Personal Injuries Covered

In the event you, someone working for you, or any other person sustain a personal injury as a result of using the PETOL tool, PETOL limits its potential liability for such a claim or injury to the fullest extent allowed by law, and disclaims and denies any liability for such personal injury.

Please be advised that some states do not allow the exclusion or limitation of liability for personal injuries, so the above limitation or exclusion may not apply to you, or the individual claiming injury.

No Other Express Warranty Applies

This PETOL LIMITED WARRANTY is the sole and exclusive warranty, express or implied for PETOL products. No employee, agent, dealer or other person is authorized to alter, modify, expand or reduce the terms of this warranty or to make any other warranty on behalf of PETOL.

Law Applicable

All matters related to the sale and/or use of the PETOL tool that is the subject of this limited warranty, along with the construction and enforcement of the terms of this limited warranty itself, shall be subject to the substantive and procedural laws of the state of Texas, not the conflicts of laws provisions of Texas, but rather the laws of Texas themselves.

Forum Selection Clause

Any dispute arising out of the sale and/or use of the PETOL tool that is the subject of this limited warranty shall be presented in the form of a claim or lawsuit to the offices of PETOL in Clifton, Bosque County, Texas. No claim or suit may be brought against PETOL, arising out of the sale and/or use of the tool, or arising out of the terms of this warranty, except in such forum. Purchase and/or use of the PETOL tool makes you subject to the

benefits and limitations of this limited warranty. Accordingly, any writ, judgment or other enforcement, obtained from a jurisdiction, county, parish, state or federal court or other country, other than the forum identified above, shall be void and unenforceable against PETOL.

Arbitration Clause

In the event of dispute or claim arises out of the sale and/or use of the PETOL tool that is the subject of this limited warranty, or arises out of the interpretation or enforcement of the terms and conditions of this limited warranty, such dispute shall be submitted to binding arbitration pursuant to the rules of the American Arbitration Association. If required to accomplish the purpose of this Arbitration clause, the purchaser hereby expressly waives any right to demand trial by jury.

Complete Agreement

This express limited warranty contains the entire agreement regarding express or implied warranties related to the PETOL tool that is the subject of it. No writing or language contained in the purchase order or any other document of the purchaser, or invoice of PETOL or any intermediate seller, shall be construed as modifying, in any way, the rights and liabilities contained in this limited warranty. PETOL expressly disclaims any obligations expressed in any customer purchase order or document that are contrary to the terms and limitations of this warranty.

Severability

If any term or limitation contained in this limited warranty is deemed unenforceable by law, then the term shall be severed from the remaining portions of the limited warranty which shall remain enforceable.

All communications to PETOL regarding the use of the tool and any aspect of the sale of the tool of this limited warranty should be addressed to PETOL.

PETOL · 4450 S. Highway 6 · P.O. Box 192 · Clifton, TX 76634

Safe Practices and Procedures

Responsibility

It is the responsibility of the employer to train the employee in the proper selection and use of tubing elevators, and to ensure that they are selected and used in that manner. A part of the job instruction program should therefore be detailed training in the proper use of tubing elevators.

"Employers are responsible for the safe condition of tools and equipment used by employees, including tools and equipment which may be furnished by employees." - (Source: OSHA 1910.242A)

Replacement Parts

Safety

While we pride ourselves on the quality and dependability that we build into PETOL tools and products, we caution users that it is only prudent to know and follow the simple rules of safety when using our products, or anyone else's.

Always follow safe practices and procedures in accordance with the recommendations of OSHA, The National Safety Council (NSC), The Hand Tools Institute (HTI), The International Association of Drilling Contractors (IADC), Etc. All applicable Governmental rules, regulations or restrictions, now in effect or which may be promulgated, take precedence over the suggestions in this publication. The information in this publication is designed to supplement standard safe practices and procedures, not in lieu of, or replacement thereof.

Safe Practices

(Source: The National Safety Council)

Failure to observe one or more of the following five safe practices accounts for most hand and powered tool accidents:

1. ALWAYS WEAR SAFETY GOGGLES TO PROTECT EYES
2. SELECT THE RIGHT TOOL FOR THE JOB
3. KEEP TOOLS IN GOOD CONDITION
4. USE TOOLS CORRECTLY
5. KEEP TOOLS IN A SAFE PLACE

Safety Goggles must always be worn by persons in any area where hand and powered tools are being used.

Never apply excess leverage to a wrench or tool by means of a "Cheater Bar". Never strike wrenches and tools with hammers or other objects.

All tools should be kept clean, inspected on a regular basis, and replaced when they show signs of wear.

Be especially careful not to place yourself in a position that could result in bodily injury in the event of a failure. Brace yourself firmly and pull rather than push when wrenching. (If necessary, to push, do so with the flat of the hand rather than gripping around the wrench.)

Never stand under or near loads being hoisted off the ground.

READ SAFE PRACTICES AND PROCEDURES MANUAL, CATALOG INFORMATION AND PRODUCT LABELING PRIOR TO OPERATION.

Safety Sources and Publications

In the interest of Safety the following sources of Safety information is furnished:

The Hand Tools Institute (HTI)
25 North Broadway
Tarrytown, New York 10591
(914) 332-0040
www.hti.org

The National Safety Council (NSC)
1121 Spring Lake Drive
Itasca, Illinois 60143-3201
(630) 285-1121
www.nsc.org

International Safety Council
1121 Spring Lake Drive
Itasca, Illinois 60143-3201
(630) 285-1121

Responsibility of Distributors

IT IS THE RESPONSIBILITY OF THE PURCHASERS OF PETOL[®] PRODUCTS TO CONVEY THE INFORMATION IN THIS PUBLICATION AND ANY OTHER INFORMATION RELATING TO THE INDIVIDUAL PRODUCT, THROUGH THE CHANNELS OF DISTRIBUTION, DOWN TO AND INCLUDING THE INDIVIDUAL USING THE PRODUCT

NOTE:

In view of the fact that the actual use determines whether safety requirements have been met, the ultimate responsibility to comply rests with the end user.

The service life of leaf chains can be altered by a variety of adverse operating conditions. The following information discusses the most important of these conditions for consideration when operating or scheduling replacement of leaf chain systems.

Overloading / Shock Loads / Side Loading

Attempting to “inch loads which are beyond the rated capacity of the tool.

Striking the tool with a hammer or other object while force is being exerted in an attempt to loosen a “frozen” joint.

Side pull can be caused by pulling or pushing on the tong in a direction that is not along a perpendicular plane, unlevelled mounting of the tong or vise, inadequate support of the part being broken out, and improper seating of the part being broken out in the tong or vise. Improper seating will occur when the diameter of the part is not consistent within the width of the tong or vise jaw.

Environmental Conditions

Wrench chains operate in widely varying environments, from wet outdoor conditions to mildly or highly corrosive industrial atmospheres. They can also be exposed to abrasives such as sand or grit.

The possible effects include:

Moisture - Corrosion and rust reduce chain strength by causing pitting and cracking.

Temperature - Very cold temperatures reduce chain strength by embrittlement.

Chemical Solutions or Vapors - Corrosive attack of the chain components' grain structure and/or the mechanical connections between the chain components (crevice corrosion) may occur. Cracking often is microscopic. Propagation to complete failure can be eventual or sudden.

Abrasives - Accelerated wearing and scoring of the articulating chain members (pins and plates) may occur, with a corresponding reduction in chain strength. Due to inaccessibility of the bearing surfaces (pin surfaces and plate apertures), wear and scoring are not readily noticeable.

These conditions, when coupled with normal chain wear and inherent residual stress (normally in the chain as constructed), can result in environmentally assisted failure. It is impossible to predict chain life under complex conditions, as the degree of hostility and its effects are dependent on many variables such as temperature, time of exposure, concentration of corrosive atmosphere or medium, degree of abrasive wear, etc. Establishing the degree and frequency of unpredictable dynamic loading is also difficult.

Normal Life Expectancy

A leaf chain's normal life expectancy can be expressed as a maximum percent of elongation. This is generally between 2% and 3% of pitch. As the chain flexes back and forth, the bearing joints (pins and inside link plates) gradually wear from articulation. As with all steel

bearing surfaces, the precision hardened steel joints of leaf chain require a constant film of oil between mating parts to prevent wear and to resist corrosion.

Lubrication

One of the most important but often overlooked factors is adequate lubrication. In addition to reducing internal friction, maintaining a film of oil on all chain surfaces will inhibit rusting and corrosion, this is important as corrosion of highly stressed, hardened steel chain components can cause a major reduction in the load capacity of leaf chain and result in link plate cracking.

Protection from corrosion is important in storage as well as in service. The factory lubricant applied to PETOL® Chain is a “Fingerprint Neutralizing Water-Displacing Corrosion Preventative.” This is an excellent rust and corrosion inhibitor for chains in storage.

Do not attempt to paint chains. Though painting may help inhibit corrosion, it will seal off critical clearances and restricts oil from reaching the pin surfaces where it is needed for good joint lubrication. Do not plate chains or chain components. Highly stressed alloy steel components are subject to hydrogen embrittlement caused by plating. Periodic relubrication of chains is the most important factor in extending the life of the chains. There is no lubricant that is ideal for all situations.

A heavy oil lubricant provides excellent protection during prolonged storage, but is messy to apply, will attract dirt and other contaminants and is messy to use. These contaminants could lead to premature abrasive wear of the moving components. When operating in dusty environments, lubricated chains will accumulate a paste like buildup of grime. At periodic intervals, this buildup should be removed by cleaning and the chain should be immediately relubricated. Do not use caustic or acid type cleaners; use a stiff brush and a certified safe petroleum base solvent.



Light oil-based lubricants penetrate into articulated joints easily but can also be washed off or rubbed off during use. A light oil-based lubricant must have periodic reapplication of the lubricant to maintain coverage.

Specialty chain lubricants (wax-based) provide excellent lubrication. They have no oily residue. They are easy to apply. They can be more expensive than other lubricants and are subject to being washed off or worn off. Wax-based lubricants must have periodic reapplication of the lubricant to maintain coverage.

The frequency of relubrication is the most important factor. It will depend on frequency of use, length of storage between uses, exposure to dust and other contaminants, and exposure to salt water or other corrosion accelerants. The end user should establish a good preventative maintenance program for relubrication of all chains and articulated components.

Periodic Inspection List for PETOL[®] Special Chain

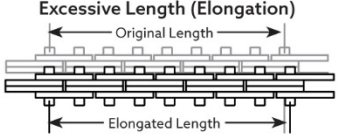
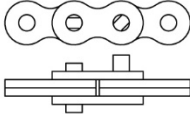
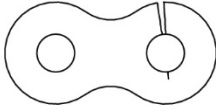
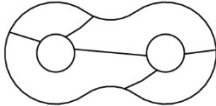
1. Prior to each use, Leaf Chain and tools should be inspected for serviceability and lubrication.
2. Use Only PETOL[™] Replacement Parts - No other parts are of comparable strength, quality, and interchangeability.

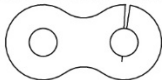
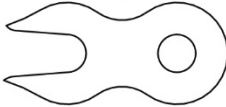
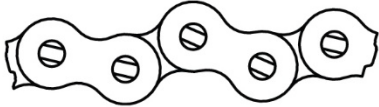
APPEARANCE AND/OR SYMPTOM	PROBABLE CAUSE	CORRECTION
<p>Excessive Length (Elongation)</p> 	<p>Normal Wear</p> <p>Permanent deformation (stretch) from overload</p>	<p>Replace chain</p> <p>Replace chain and correct cause of overload</p>
<p>Abnormal Protrusion of Pins</p> 	<p>Overloading</p> <p>Inadequate lubrication</p> <p>Side Loading</p>	<p>Replace chain and correct cause of overload</p> <p>Replace chain and improve lubrication</p> <p>Replace chain and correct cause of side load</p>
<p>Cracked Plates (Fatigue)</p> 	<p>Overloading</p> <p>Side Loading</p>	<p>Replace chain and correct cause of overload</p> <p>Replace chain and correct cause of side load</p>
<p>Arc-Like Cracked Plates (Stress Corrosion)</p> 	<p>Severe rusting or exposure to acidic or caustic medium, plus static stress at press fit between pin and plate.</p>	<p>Replace chain and protect from hostile environment</p>
<p>Enlarged Holes</p> 	<p>Overloading</p>	<p>Replace chain and correct cause of overload</p>
<p>Cracked Plates (Corrosion Fatigue) Perpendicular to Pitch Line, plus rust or other evidence of chemical corrosion</p> 	<p>Corrosive Environment</p>	<p>Replace chain and protect from hostile environment</p>
<p>Fractured Plates (Tension Mode)</p> 	<p>Overloading</p>	<p>Replace chain and correct cause of overload</p>
<p>Tight Joints</p> 	<p>Dirt or foreign substance packed in joints</p> <p>Corrosion and rust</p> <p>Bent Pins</p>	<p>Clean and relube</p> <p>Replace chain and protect from hostile environment</p> <p>Replace chain</p>

Safety Precautions

1. Always wear safety goggles to protect eyes.
2. Select the right tool for the job.
3. Keep tools in good condition.
4. Use tools correctly.
5. Keep tools in a safe place.
6. Wear protective clothing, gloves and safety shoes as appropriate.
7. Use lengths of assembled chain. Do not build lengths from individual components.
8. Do not attempt to rework damaged chain by replacing only the components obviously faulty. The entire chain may be compromised and should be discarded.
9. Never electroplate assembled leaf chains or components. Plating will result in failure from hydrogen embrittlement.
10. Do not weld any chain or component. Welding spatter should never be allowed to come into contact with chain or components.
11. Leaf chains are manufactured exclusively from heat-treated steels and therefore must not be annealed. If heating a chain with a cutting torch is absolutely necessary for removal, the chain should not be reused.
12. Inspect chains frequently and regularly for link plate cracking, pin turning, pin protrusion and corrosion.
13. Use only PETOL[®] replacement parts to ensure proper strength.

Installation

Location

The PETOL[®] HYDRA-TORK[®] Unit should be located in an area with adequate room to work the downhole tools. The unit may be located indoors or outdoors upon solid level ground or a finished shop floor. No special foundation is required.

Setup

Locate the hydraulic console in a convenient location and connect the hoses to the main hydraulic cylinder and the lift cylinder. Attach the control cable from the main cylinder to the receptacle on the side of the console.

Electrical Wiring

Connect electrical power to the console at the disconnect switch located in the access door of the main electrical panel at the top of the console. The electrical supply should be made by a qualified electrician in accordance with all applicable local codes and standards. If the unit voltage must be changed to match the available supply voltage (e.g. after relocation), change the motor wiring at the motor in the lower section of the console, change the primary leads on the control transformer in the main electrical panel, and change the motor starter heater elements in the main electrical panel. The spare parts list describes the heater elements needed for all voltages.

Startup

Verify that the oil level is within the operating limits as shown on the console sight glass. **Use Chevron AW-ISO46 or equal (30 gallons).** Turn on the disconnect switch to power up the console. Start the hydraulic pump and immediately press any one of the cylinder control buttons. If the cylinder does not move and if no hydraulic pressure is indicated (1) immediately turn off the power; (2) lock out the power supply to the console; and (3) reverse any two of the power supply leads to obtain the correct pump rotation.

If the main cylinder will only extend and not retract (1) turn off the power; (2) lock out the power to the console; and (3) reverse the hoses attaching the console to the main cylinder.

If the lift cylinder operates opposite from the switch functions (1) turn off the power; (2) lock out the power to the console; and (3) reverse the hoses attaching the console to the lift cylinder.

Cycle the cylinder several times to clear the system of any entrapped air.

Operation

Controls

The operating controls are shown on Figures 1 and 2 on page 19.

The disconnect switch is used to disconnect electrical power to the controls. When this switch is on, the motor may be started.

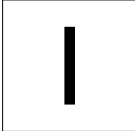

The **POWER ON** switch will start the hydraulic pump motor. It contains an indicator light to show that the motor is on.

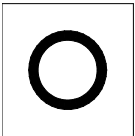

The **POWER OFF** switch is used to stop the motor.

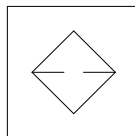

The **FILTER** indicator light is used to monitor the hydraulic filter. If this light is on while a cylinder is traveling the hydraulic filter element, located in the lower portion of the console, is dirty and must be replaced. **Use Schroeder MS-7 element or equal.**

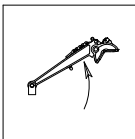

The **TONG LIFT** (optional) button is used to raise the tong for loading or removing the workpiece.

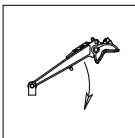

The **TONG LOWER** (optional) button is used to lower the tong for latching on the workpiece.

The **LIFT-TORQUE** (optional) selector switch changes the function from raising or lowering the tong to applying torque and ratcheting.

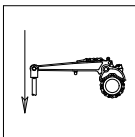

The **TONG ENGAGE** button is used to control operation of the main cylinder. Press the **TONG ENGAGE** button to retract the cylinder and apply torque.

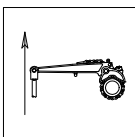

The **TONG RATCHET** button is used to control operation of the main cylinder. Press the **TONG RATCHET** button to extend the cylinder in preparation for applying torque.

The **HAND-AUTO** (optional) selector switch changes the mode of the console from manual to automatic cycling.

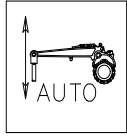

The **AUTO START** (optional) button is used to control the automatic cycling of the main cylinder. Press the **AUTO START** button to start the cylinder



The **AUTO STOP** (optional) button is used to control the automatic cycling of the main cylinder. Press the **AUTO STOP** button to cancel the automatic

The pressure control knob is used to adjust the overall system pressure. Turn the knob clockwise to increase pressure or counter-clockwise to decrease system pressure.

WARNING: Never operate the tong with a pressure higher than required to perform the make up or break out operation. Operation at excessive pressure may damage the downhole tool and/or injure personnel.

The hydraulic pressure gauge is used to indicate the current system pressure in psi. Conversion charts for equating the hydraulic pressure in psi to the torque output in ft-lb. follows:

TORQUE-PRESSURE CONVERSION

TORQUE (ft-lbs)	PRESSURE (psig)	TORQUE (ft-lbs)	PRESSURE (psig)
1,600	210	5,800	750
1,800	230	6,000	780
2,000	260	6,200	800
2,200	290	6,400	830
2,400	310	6,600	860
2,600	340	6,800	880
2,800	360	7,000	910
3,000	390	7,500	970
3,200	420	8,000	1,040
3,400	440	8,500	1,100
3,600	470	9,000	1,170
3,800	490	9,500	1,230
4,000	520	10,000	1,300
4,200	550	10,500	1,360
4,400	570	11,000	1,430
4,600	600	11,500	1,490
4,800	620	12,000	1,560
5,000	650	12,500	1,620
5,200	680	13,000	1,690
5,400	700	13,500	1,750
5,600	730	14,000	1,820

Hydraulic Console



Control Panel

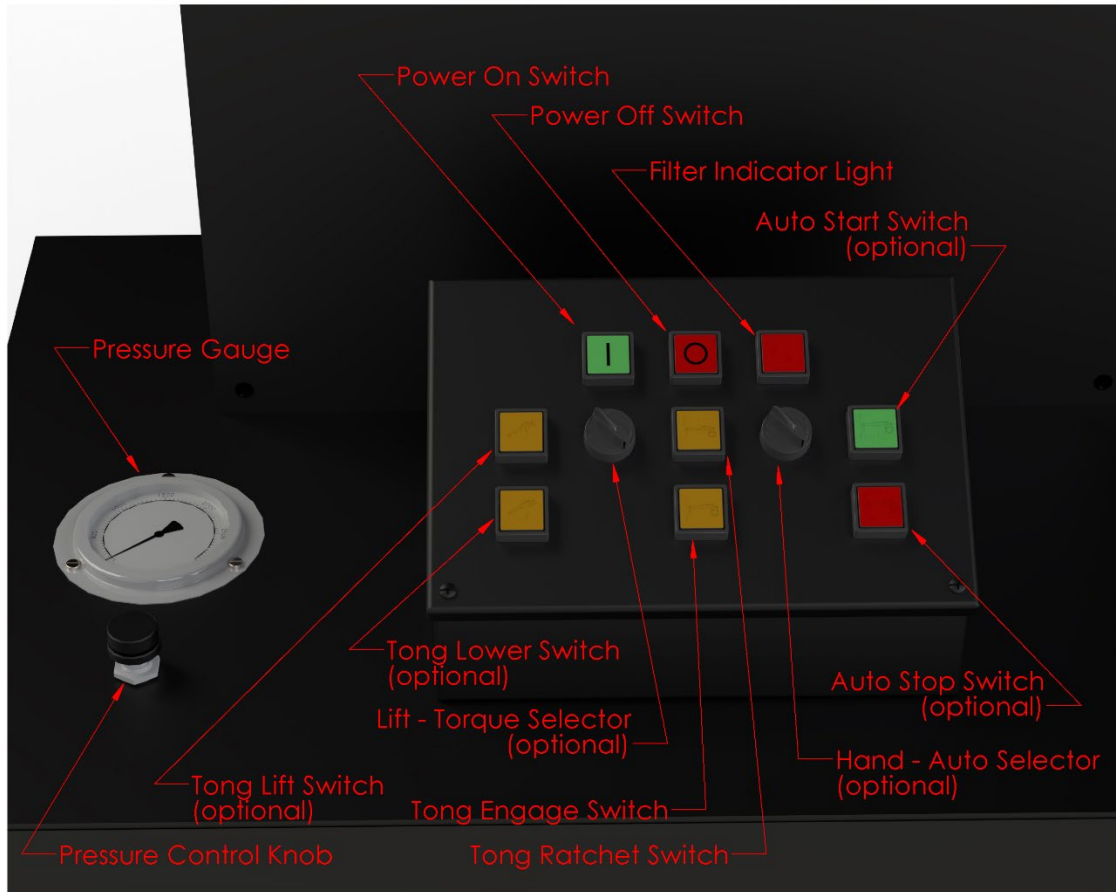

Loading

To load the downhole tool in the unit, slide the vise left or right as needed. Adjust the vee-saddle to support the tool when set into the vise. Set the tool into the vise. Position the tong for make up or break out as needed and set the tong onto the tool. Adjust the vise and tong as described and latch the vise chain and tong chain.

CAUTION: The vee-saddles must be used to support the tool while torquing.

Vise and Tong Adjustment

Release the cam lock on the tong and vise by depressing the cam lever and moving the pawl to the unlocked position. Slide the chain through the tong or vise as needed to latch the chain screw nut into the jaw. Move the pawl lever to the locked position and release the cam lever. Check that the cam lever is latched. Tighten the chain screw nut on the vise until hand tight. Tighten the chain screw nut on the tong until it is hand tight and then loosen the chain screw nut on the tong 1/2 turn to provide proper ratcheting.

Vise Adjustment

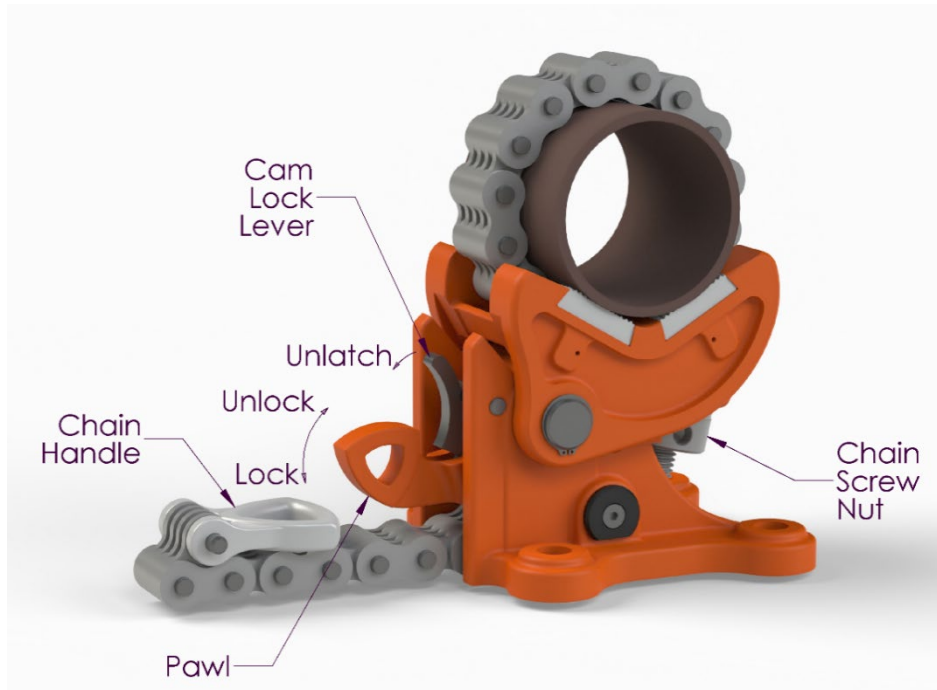

Breaking Out

Load the tool and adjust the tong and vise as described above. Fully ratchet the tong. Turn the pressure control knob fully counter-clockwise, engaging the tong. When the tong stops, begin increasing the system pressure by turning the pressure control **slowly** clockwise. Keep increasing the system pressure until the connection is broken loose **or the working load of the tong is reached. Do not exceed the rating of the tong. Consult with PETOL® as needed for help with the toughest break out jobs.** After the initial break out, ratchet the tong fully and then alternately engage / ratchet the tong until the connection is fully loosened.

Making Up

Load the tool and adjust the tong and vise as described above. Make up the connection hand tight using PETOL-TITAN® Chain Tongs. While pressing the **TONG RATCHET** button with the cylinder fully extended, adjust the pressure control knob until the desired make up torque is displayed. Engage the tong. If the cylinder fully retracts without stalling, cycle the tong (ratchet / engage). Continue until the cylinder stalls.

Calibration

Periodic calibration of the digital display and recorder outputs is recommended to maintain the highest possible accuracy. The following procedures should be used for calibration.



WARNING! If the calibration is done using a tong on the unit, the workpiece MUST be capable of safely resisting the maximum applied torque. DO NOT EXCEED RATED LOAD FOR THE UNIT DURING CALIBRATION.

1. Connect a calibrated load cell between the cylinder and the tong handle. The cylinder may be removed from the unit and connected to any structure capable of safely supporting this load.
2. Install a workpiece (pipe or solid bar) capable of withstanding the full torque
3. Apply pressure to the cylinder. The table below lists the recommended pressure values and the theoretical display and analog output values.
4. Record the displayed torque and output voltage for each calibration point.
5. Adjust the meter as needed using the procedures listed below. Adjust the meter display prior to the analog output, as the meter controls will also affect the analog output.
6. Return the unit to service.

Recommended Calibration Points

Gauge Pressure (psi)	Cylinder Force (lbs)	Indicated Torque (ft-lbs)	Analog Output (volts)
0	0	0	0
290	1000	2250	1.500
580	2000	4500	3.000
880	3000	6750	4.500
1170	4000	9000	6.000
1460	5000	11250	7.500
1810	6200	13950	9.300

The following steps are used to adjust the meter calibration. Press the button indicated until the display shows the value in quotation marks.

- ↵ “INt” ← ◀ ▶ “LINR” ↵ ◀ ▶ “MANL” ↵ “Rd.1” ↵ 0000 (torque at no load)
- “IN.1” ↵ XXXX (transducer signal at no load)
- “Rd.2” ↵ 0225 (torque at 1,000 lbs)
- “IN.2” ↵ XXXX (transducer signal at 3,000 lbs)
- “Rd.3” ↵ 0450 (torque at 2,000 lbs)
- “IN.3” ↵ XXXX (transducer signal at 5,000 lbs)
- “Rd.4” ↵ 0675 (torque at 3,000 lbs)
- “IN.4” ↵ XXXX (transducer signal at 8,000 lbs)
- “Rd.5” ↵ 0900 (torque at 4,000 lbs)
- “IN.5” ↵ XXXX (transducer signal at 10,000 lbs)
- “Rd.6” ↵ 1125 (torque at 5,000 lbs)
- “IN.6” ↵ XXXX (transducer signal at 13,000 lbs)
- “Rd.7” ↵ 1395 (torque at 6,200 lbs)
- “IN.7” ↵ XXXX (transducer signal at 15,240 lbs)

Parts List

The following drawings, diagrams, and parts lists describe all parts, which may be needed as replacement items. Where appropriate, standard industrial, electrical, and hydraulic components have been used. Should a standard industrial item need replacing, the item may be purchased locally. To assist you in obtaining parts, the OEM component manufacturer and model numbers are shown on the parts list. Of course, all replacement parts will be supplied by PETOL® if you prefer to order from us.

All tong, vise, and chain components are manufactured only by PETOL. DO NOT ATTEMPT TO SUBSTITUTE THESE COMPONENTS. The unit will not work properly unless these components are matched to the specific application. Consult our factory as your requirements change. Any non-PETOL substitutions of these components void all warranties and subject the user to assumption of liabilities resulting from subsequent use.

Final Assembly Dimensions and Parts List (standard base)

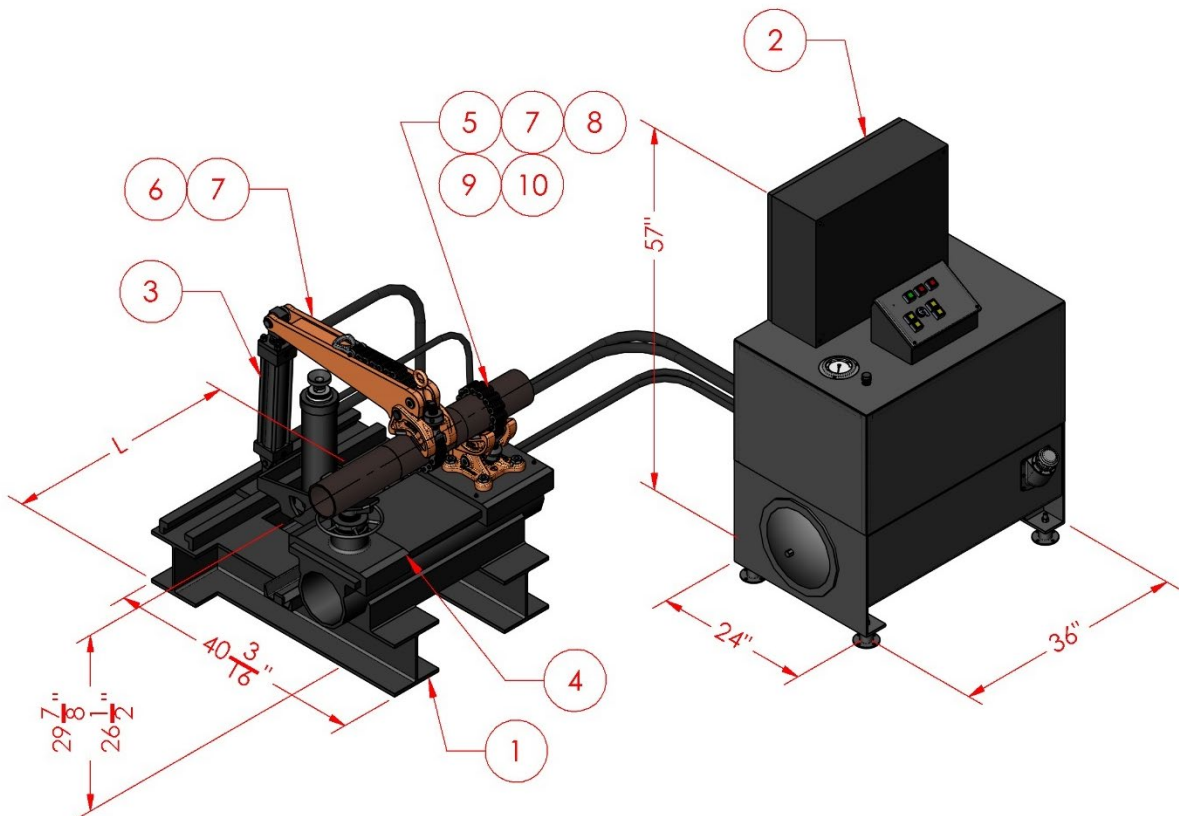

Final Assembly Dimensions and Parts List (skid mount)

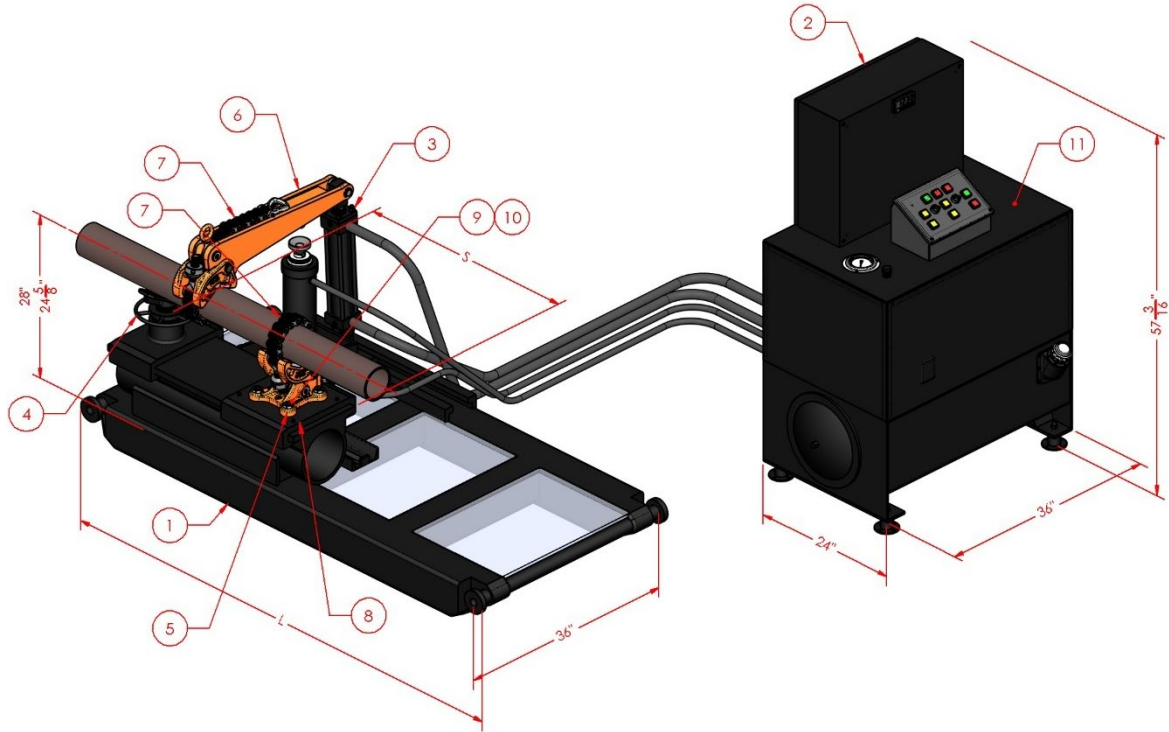

Final Assembly Parts List

Item	Qty.	Part Number	Description	Notes
1	1	UHBASE-115H-01	Standard base	Options 000, 001, 002, 012
1	1	UHBASE-115H-02	Skid base	All options
1	1	UHBASE-115H-03	Standard base	All options
1	1	UHBASE-115H-04	Standard base	All options
1	1	UHBASE-115H-05	Standard base	All options
1	1	UHBASE-115H-06	Skid base	All options
1	1	UHBASE-115H-07	Standard base	All options
2	1	UHCN115H000XXXXX	Console, no options	XXXXX = VoltageHz pages 22-27
2	1	UHCN115H001XXXXX	Console, option 1	XXXXX = VoltageHz pages 22-27
2	1	UHCN115H002XXXXX	Console, option 2	XXXXX = VoltageHz pages 22-27
2	1	UHCN115H003XXXXX	Console, option 3	XXXXX = VoltageHz pages 22-27
2	1	UHCN115H012XXXXX	Console, options 1, 2	XXXXX = VoltageHz pages 22-27
2	1	UHCN115H013XXXXX	Console, options 1,3	XXXXX = VoltageHz pages 22-27
2	1	UHCN115H023XXXXX	Console, options 2, 3	XXXXX = VoltageHz pages 22-27
2	1	UHCN115H123XXXXX	Console, options 1,2,3	XXXXX = VoltageHz pages 22-27
3	1	UHCY-115H-000	Cylinder assembly	Options 000, 001 page 28
3	1	UHCY-115H-002	Cylindder assembly	Options 002, 012 page 28
3	1	UCC-H	Cylinder carriage	Options 023, 123 pages 29-30
3	1	UCC-I	Cylinder carriage	Options 003, 013 pages 29-30
4	1	UHVSA-115H	Vee saddle assembly	See page 31
5	1	TVA115H	Vise assembly	See page 32
6	1	UVTDA115H	Tong assembly	See page 33
7	2	151-45-25T	Chain assembly	See page 34
8	1	UVS-1-12-12	Vise slide	
9	4	HB61	Flathead cap screw	3/4-10UNC x 2-1/2 long
10	4	HXN003	3/4-10UNC hex nut	
11	4	HXG001	Grease insert	

Base Dimensions

Base Part Number	Description	Overall Length (L)	Slide Length (S)
UHBASE-115H-01	Standard base, options 000, 001, 002, 012	36	36
UHBASE-115H-02	Skid base, all options	78	36
UHBASE-115H-03	Standard base, all options	144	144
UHBASE-115H-04	Standard base, all options	72	72
UHBASE-115H-05	Standard base, all options	36	36
UHBASE-115H-06	Skid base, all options	190-1/2	180
UHBASE-115H-07	Standard base, all options	180	180



Console Assembly Parts List

Item	Qty.	Part Number	Description	Make / Model	Notes
1	1	UHCH-115H-000	Hydraulic schematic		Options 000, 001, 002, 012 Pages 23-24
1	1	UHCH-115H-003	Hydraulic schematic		Options 003, 013, 023, 123 Pages 23-24
2	1	UHCN-P1-00	Control panel		Options 000, 001 page 25
2	1	UHCN-P1-23	Control panel		Options 002, 012 page 25
2	1	UHCN-P1-23	Control panel		Options 003, 013 page 25
2	1	UHCN-P1-23	Control panel		Options 023, 123 page 25
3	1	UHCN-P2-XXX	Main electrical panel XXX = options		Pages 26-27
4	30 gal.	UHCH-OIL	Hydraulic oil	Chevron AW-ISO46	Or equal

LB = LIFT CYLINDER, BLIND END
 LR = LIFT CYLINDER, ROD END
 MB = MAIN CYLINDER, BLIND END
 MR = MAIN CYLINDER, ROD END

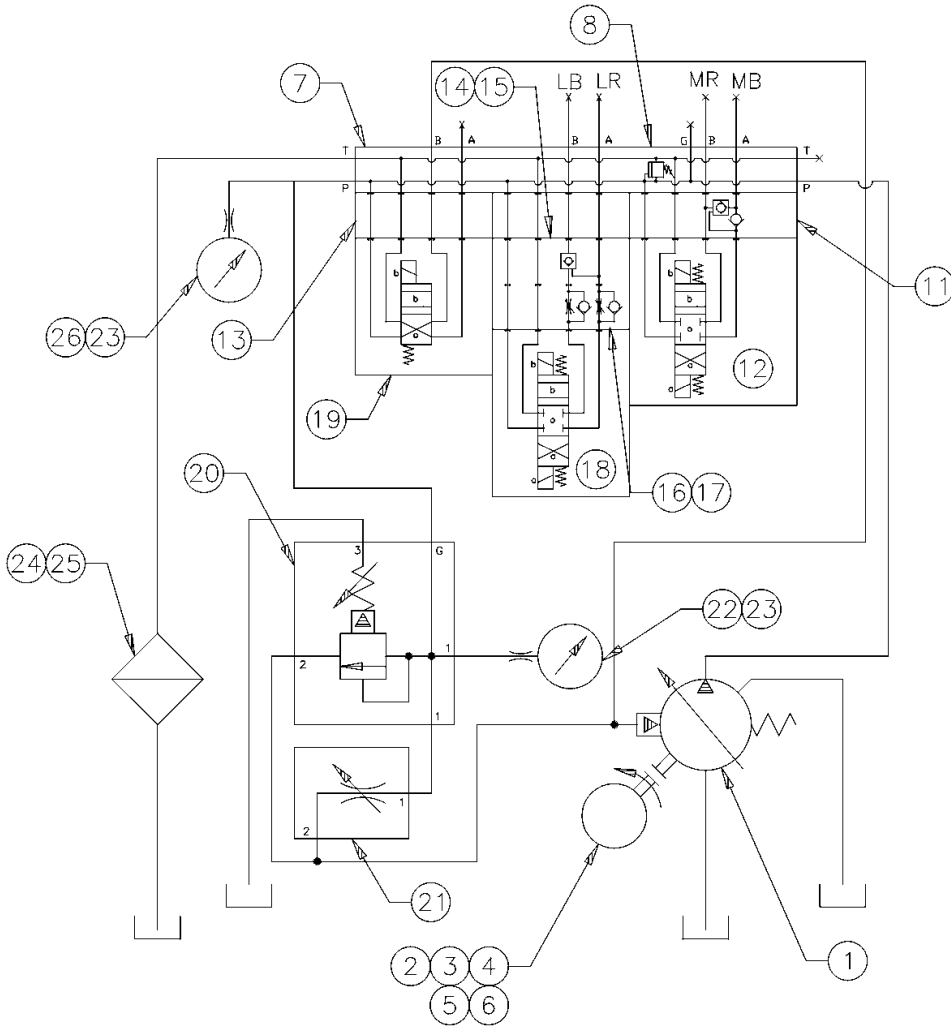

Hydraulic Schematic

Hydraulic Schematic Parts List

Item	Qty.	Part Number	Description	Make / Model	Notes
1	1	UHCH-P32	Pump	Bosch Rexroth AA10VS0180R/31R- VKC62N00	
2	1	UHCH-M07	Motor	U. S. Motor U5P2DC	Or equal
3	1	UHCH-M08	Motor coupling	Magnalloy M20010408	Or equal
4	1	UHCH-M03	Pump coupling	Magnalloy M20012406	Or equal
5	1	UHCH-M04	Coupling insert	Magnalloy M270N	Or equal
6	1	UHCH-P33	Adaptor	Magnalloy M182472A(4A) (modified)	Or equal
7	1	UHCH-V40	Manifold	Sun VSN	Or equal
8	1	UHCH-V13	Relief valve	Sun RPEC-LAN (2200 PSI)	Or equal
11	1	UHCH-V41	Regenerative valve	Sun YDCF-XCN-AA	
12	1	UHCH-V12	Directional valve	Wandfluh WDMFA06-ACB-R24	
14	1	UHCH-V27	P.O. check body	Sun EBA	Or equal Option 3 only
15	1	UHCH-V17	P.O. check valve	Sun CKCB-XCN	Or equal Option 3 only
16	1	UHCH-V55	Reducing valve body	Sun ZTT	Or equal Option 3 only
17	2	UHCH-V54	Reducing valve cartridge	Sun PRDR-LAN	Or equal Option 3 only
18	1	UHCH-V12	Directional valve	Wandfluh WDMFA06-ACB-R24	Option 3 only
19	1	UHCH-V11	Pump loading valve	Wandfluh WDMFA06-AC2-R24	
20	1	UHCH-V02	Pressure control	Sun RSDC-LAN-EHI	
21	1	UHCH-V03	Power limit valve	Sun NFCC-LDN-GAI	
22	1	UHCH-G02	Pressure gauge	Wika 213.40 4" FF-LBM 2000psi	Or equal
23	1	UHCH-G05	Gauge snubber	Cajon SS-4-SA-EW	Or equal
24	1	UHCH-B03	Filter element	Hycon MF BN 80G10A1.0/5.2	Or equal
25	1	UHCH-B02	Filter switch	Hycon VR2C	Or equal

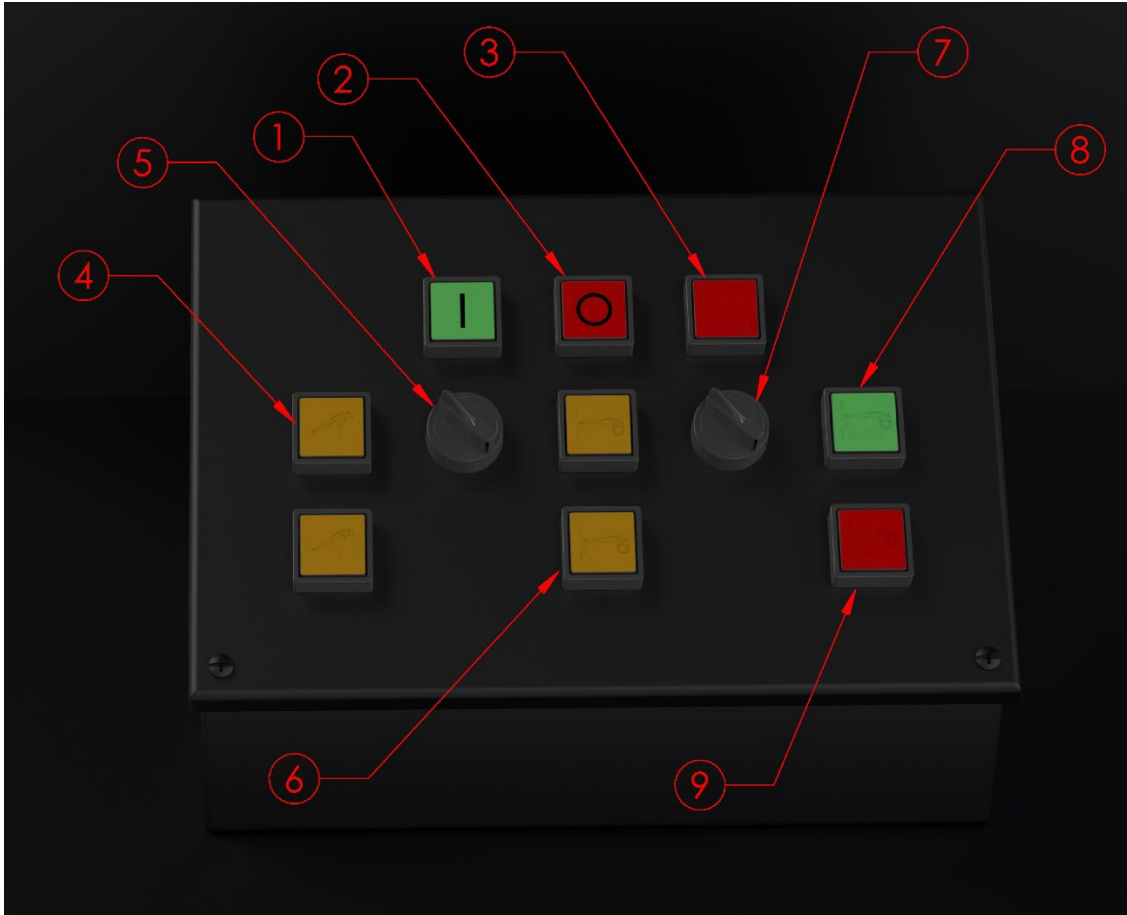

Control Panel Parts List

Item	Qty.	Part Number	Description	Make / Model	Notes
1	1	UHCE-S16	Push button switch	Fuji AR22F0M-10E3G	
2	1	UHCE-S17	Push button switch	Fuji AR22E0M-01E3R	
3	1	UHCE-S18	Push button switch	Fuji AR22F0M-01E3R	
4	2	UHCE-S19	Push button switch	Fuji AR22F0M-20E3Y	Option 3 only
5	1	UHCE-S20	Selector switch	Fuji AR22PR-211B	Options 3 only
6	2	UHCE-S19	Push button switch	Fuji AR22F0M-20E3Y	
7	1	UHCE-S20	Selector switch	Fuji AR22PR-211B	Option 2 only
8	1	UHCE-S16	Push button switch	Fuji AR22F0M-10E3G	Option 2 only
9	1	UHCE-S17	Push button switch	Fuji AR22E0M-01E3R	Option 2 only

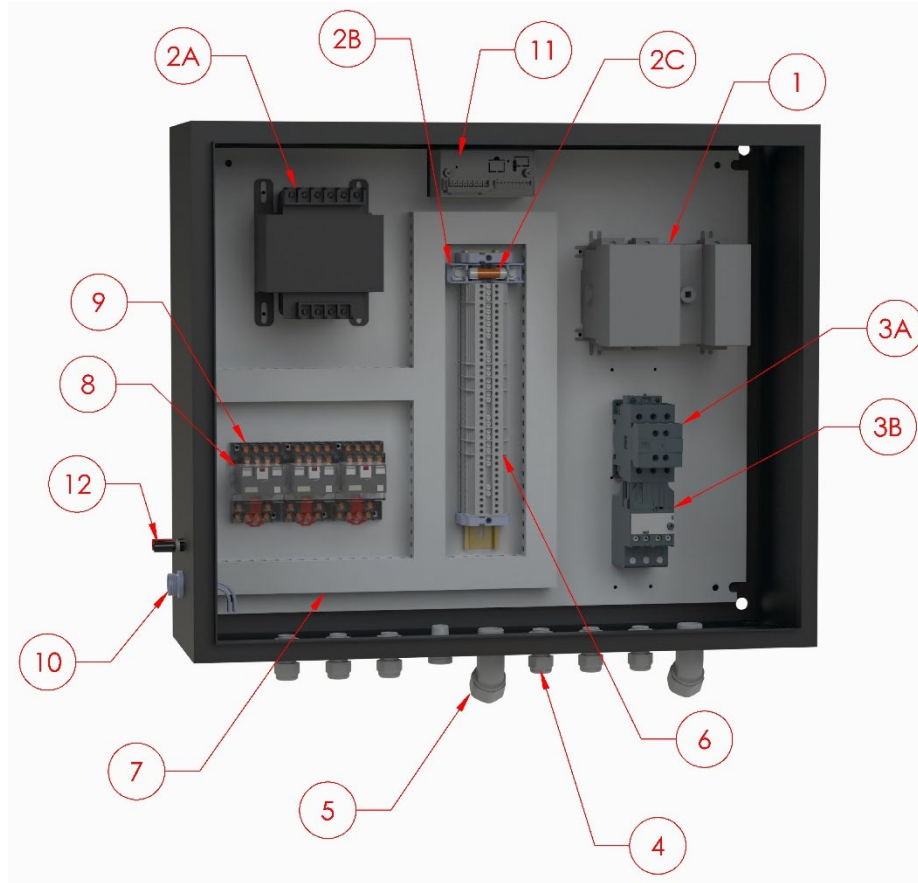

Main Electrical Panel Parts List

Item	Qty.	Part Number	Description	Make / Model	Notes
1A	1	UHCE-S12	Disconnect switch	ABB OS30FAJ12	
1B	3	UHCE-F2	Fuse, 190V, 208V, 230V	Bussmann LPJ-25	Or equal
1B	3	UHCE-F4	Fuse, 380V	Bussmann LPJ-15	Or equal
1B	3	UHCE-F6	Fuse, 380V	Bussmann LPJ-10	Or equal
2A	1	UHCE-X6	Transformer	Micron B250- 2262-GAF	
2B	1	UHCE-X5	Fuse block	Automation Direct BCM503-1PQ-1	Or equal
2C	1	UHCE-F13	Fuse	Bussmann FNQ-R-12	Or equal
3A	1	UHCE-M07	Starter	ABB AF16-30-10-41	
3B	3	UHCE-M08	Overload Relay	ABB EF19-18.9	
4A	As req'd	UHCE-W18	Cord connector	Hubbell SHC1011	Or equal Option 2 only

4B	As req'd	UHCE-W24	3/8" sealing ring	Thomas & Betts 5261	Or equal
4C	As req'd	UHCE-W27	3/8" lock nut	Thomas & Betts 140	Or equal
5A	2	UHCE-W23	3/4" x 45° liquid-tight conduit conn.	Thomas & Betts 5243	Or equal
5B	2	UHCE-W25	3/4" sealing ring	Thomas & Betts 5263	Or equal
5C	2.25 ft	UHCE-W26	3/4" liquid-tight conduit		
6A	As req'd	UHCE-W08	Terminal block	Allen-Bradley 1492-W3	
6B	As req'd	UHCE-W09	Jumper, 10 pole	Allen-Bradley 1492-CJ5-10	
6C	2	UHCE-W10	End anchor	Allen-Bradley 1492-EA35	
6D	1	UHCE-W11	End barrier	Allen-Bradley 1492-EB3	
6E	1	UHCE-W12	Mounting rail	Allen-Bradley 199-DR1	
6F	As req'd	UHCE-W13	Partition plate	Allen-Bradley 1492-PP3	
7A	1	UHCE-W15	Wiring duct	Hoffman A-100100WH	Or equal
7B	1	UHCE-W16	Wiring duct cover	Hoffman A-100CWH	Or equal
8	3	UHCE-R6	Relay, 4PDT	Automation Direct 784-4C-24A	Option 2 only
9	3	UHCE-W51	Relay socket	Automation Direct 784-4C-SKT-1	Option 2 only
10	1	UHCE-W31	Receptacle	Hubbell HB1401SB	
11	1	UHCE-I16	Digital panel meter	Newport INF-B-A	Option 1 only
12	1	UHCE-W44	Dual binding post	Newark 35N847	Or equal Option 1 only

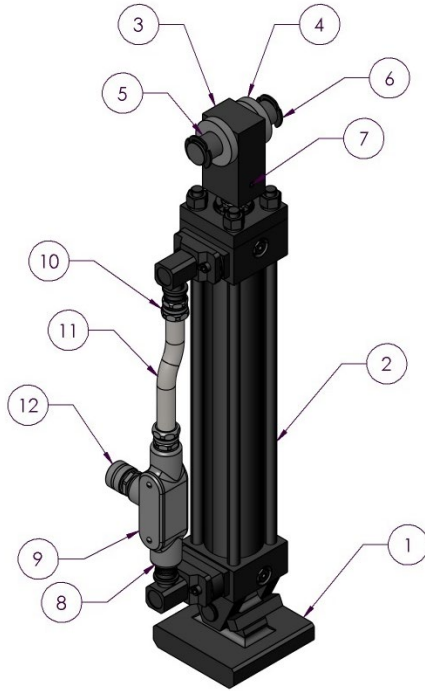

Cylinder Assembly Parts List

Item	Qty.	Part Number	Description	Make / Model	Notes
1	1	UHCY-115H-EB	Eye bracket		
2	1	UHCY-115H-C0	Cylinder	Parker 2.50CBB2HHNAU1S34AC14.00	Options 000, 001
2	1	UHCY-116H-3	Cylinder	Parker 2.50CBB2HLUS34AC14.000 B24CGG24AGG	Options 002, 012
3	1	UHCY-115H-RE	Rod eye	Vickers/Aeroquip S-660	Or equal
4	2	UHCY-115H-HB	Bushing		
5	1	HP329	Handle pin		
6	2	HXKR100	Klipring	Waldes-Truark 5304-100	Or equal
7	1	HXP014	Spring pin		1/4 x 2
8	1	UHCE-W38	1/2" close nipple		Options 002, 012
9	1	UHCE-W37	Conduit body	McMaster-Carr 9190K81 OR EQUAL	Options 002, 012
10	2	UHCE-W39	1/2" EMT connector	Thomas & Betts 5121	Options 002, 012 Or equal
11	0.70	UHCE-W36	1/2" EMT conduit		Options 002, 012
12	1	UHCE-W43	Cord connector	Hubbell SHC1023	Options 002, 012 Or equal
13	1	UHCE-W32	Control cable	Hubbell HC1420SA	Options 002, 012
14	2	UHCH-H10	Hose assembly	Gates 8C2AT-8MP-8MPX-120	Or equal (not shown)

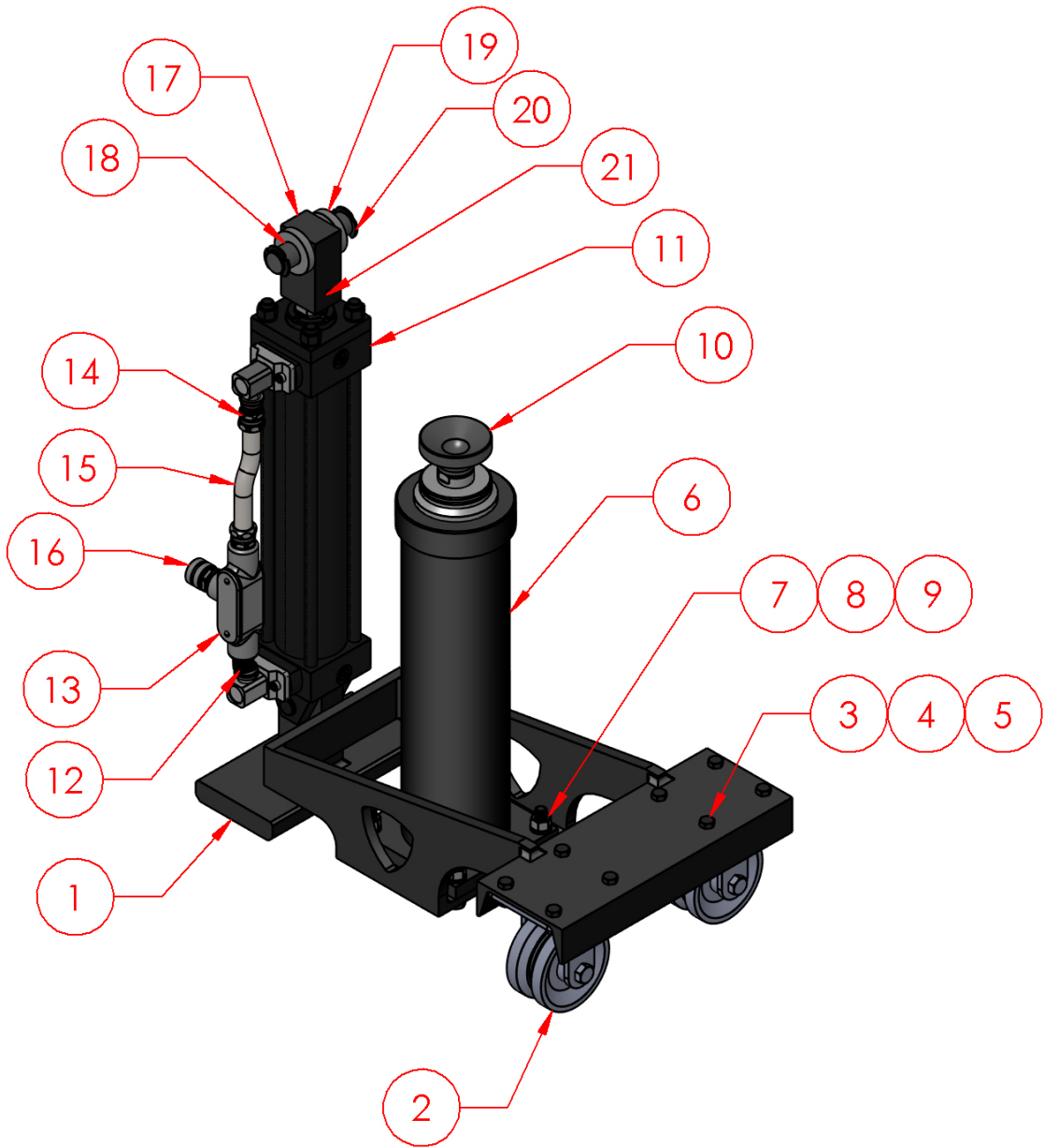

Cylinder Carriage Parts List

Cylinder Carriage Parts List

Item	Qty.	Part Number	Description	Make / Model	Notes
1	1	UCC-H-1	Carriage arm		
2	2	UCC-A-2	Caster	McMaster-Carr 2453T1	Or equal
3	8	HXS006	Hex bolt, 3/8-16UNC x 1		
4	8	HXW006	Lockwasher, 3/8"		
5	8	HXN044	Hex nut, 3/8-16UNC		
6	1	UCC-D-5	Lift cylinder	Westcraft 495250-1	
7	4	HXS007	Hex bolt, 1/2-13UNC x 1-3/4		
8	4	HXN043	Hex nut, 1/2-13UNC		
9	4	HXW005	Lockwasher, 1/2"		
10	1	UCC-D-4	Lift socket		
11	1	UHCY-115H-C0	Cylinder	Parker 2.50CBB2HHNAU1S34AC14.00	Options 000, 001
11	1	UHCY-116H-3	Cylinder	Parker 2.50CBB2HLUS34AC14.000 B24CGG24AGG	Options 002, 012
12	1	UHCE-W38	Galvanized nipple, 1/2" x close		Options 023, 123
13	1	UHCE-W37	Conduit body		Options 023, 123
14	2	UHCE-W39	Conduit connector	Thomas & Betts 5121	Options 023, 123 Or equal
15	1.80 ft	UHCE-W36	EMT conduit, 1/2"		Options 023, 123
16	1	UHCE-W43	Cord connector	Hubbell SHC1023	Options 023, 123 Or equal
17	1	UHCY-115H-RE	Cylinder rod eye	Vickers/Aeroquip S-660	
18	1	HP329	Handle pin		
19	2	UHCY-115H-HB	Handle bushing		
20	2	HXKR100	Klipring	Truarc 5304-100	Or equal
21	1	HXP014	Spring pin	1/4 x 2	
22	1	UHCE-W32	Control cable	Hubbell HC1420SA	Options 023, 123 Or equal
23	2	UHCH-H09	Hose assembly	Gates 8C2AT-6MP-8FJX-240	Or equal
24	2	UHCH-H10	Hose assembly	Gates 8C2AT-8MP-8MPX-120	Or equal



Vee Saddle Assembly Parts List

Item	Qty.	Part Number	Description	Make / Model	Notes
1	1	UHVSB-115H	Vee saddle slide		
2	1	UHVSH-115H	Vee saddle head		
3	1	UHVSN-115H	Vee saddle nut		

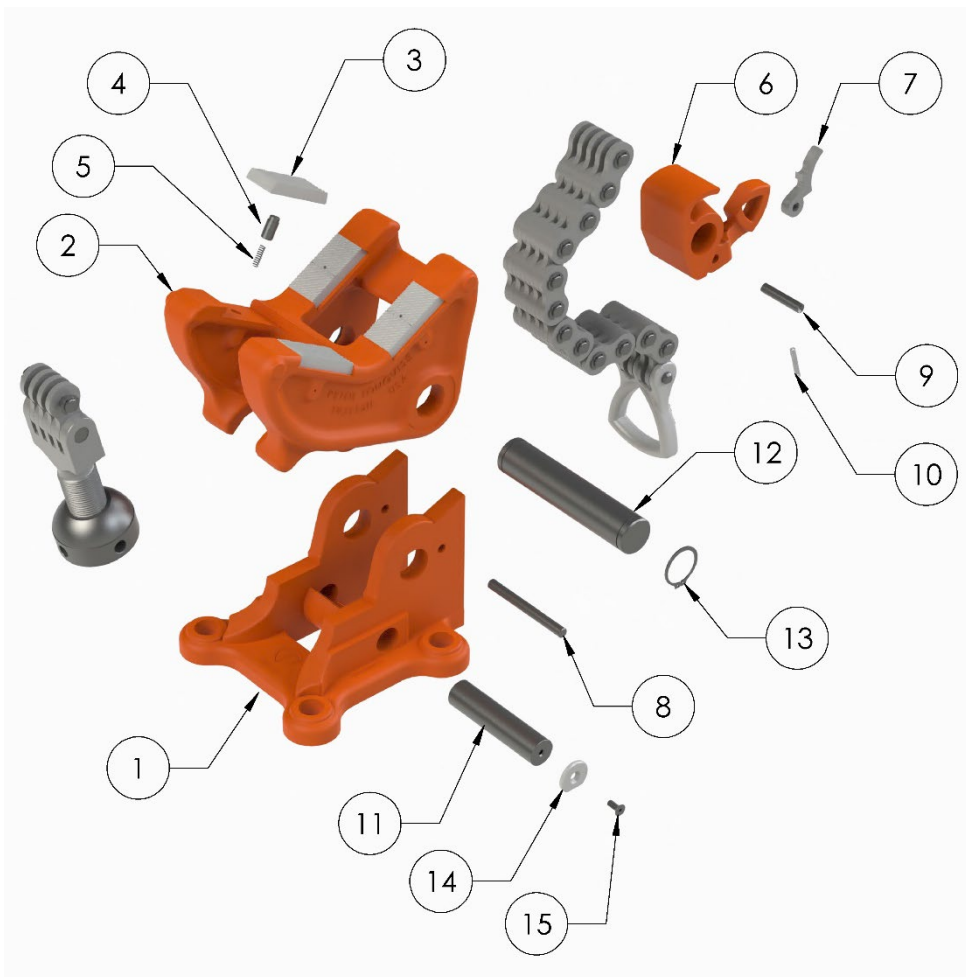

Vise Assembly Parts List

Item	Qty.	Part Number	Description
1	1	TVB115H	Base
2	1	TVJ115H	Jaw
3	4	HI04D	Diamond point insert
4	4	HP903	Insert key
5	4	HS20S	Insert key spring
6	1	TVP115	Pawl
7	1	TVL116	Pawl latch
8	1	HP297	Pawl latch pin
9	1	HP026	Pawl latch rivet
10	1	HS25	Pawl latch spring
11	1	HP274	Base pin
12	1	HP292	Jaw pin w/ kliplings
13	2	HXRR125	Jaw pin klipring only
14	2	HP274-RP	Base pin retaining plate
15	2	HXS090	Retaining plate screw

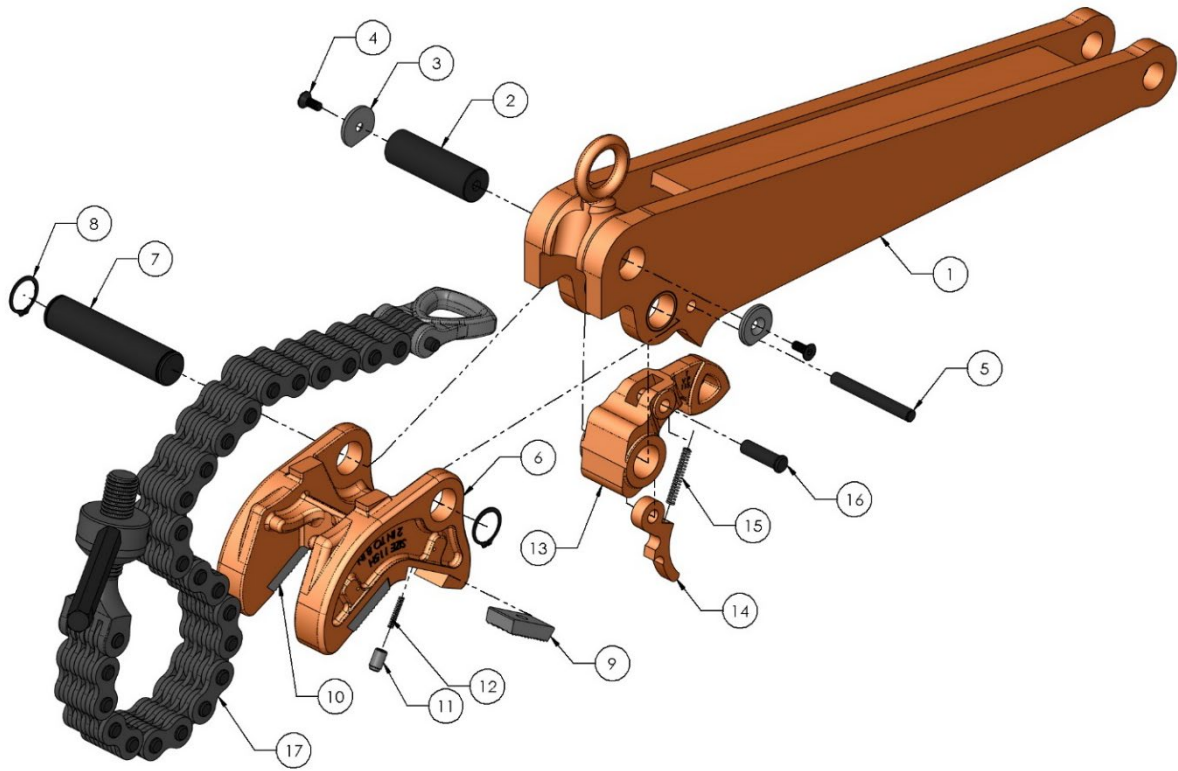

Tong Assembly Parts List

Item	Qty.	Part Number	Description
1	1	VTDH115H	Handle (without option 3)
1	1	UVTDA115H	Handle (option 3)
2	1	HP356	Handle lock pin
3	2	HP274-RP	Lock pin retaining plate
4	2	HXS090	Retaining plate screw
5	1	HP297	Pawl latch pin
6	1	TVJ115H	Jaw
7	1	HP292	Handle – jaw pin with retaining rings
8	2	HXRR125	Jaw pin retaining ring only
9, 10	4	HI04D	Diamond point insert (standard)
9, 10		HI04K	Knurled insert (optional)
10		HI04B	Blank insert (optional)
11	4	HP903	Insert key
12	4	HS20S	Insert key spring
13	1	TVP115	Pawl
14	1	TVL116	Pawl latch
15	1	HS25	Pawl latch spring
16	1	HP026	Pawl latch rivet
17	1	151-45-25T	Chain assembly (see page 34 for parts)

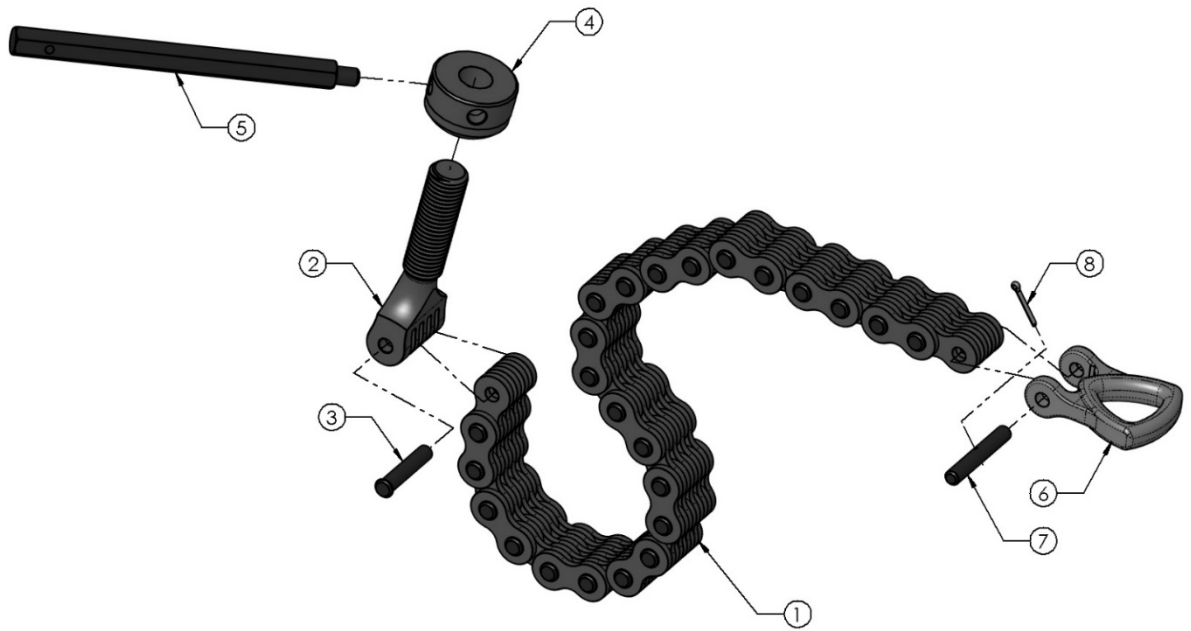

PETOL® Special Chain Parts List

Item	Part No.	Description
1	151-45-25	Special chain only
2	HV07-45	Chain screw
3	HP236	Chain screw rivet
4	HN05	Chain screw nut
5	HP951	Chain nut lever
6	HD2-45	Chain handle
7	HP280	Chain handle pin with cotter
8	HXC002	Chain handle pin cotter only

Electrical Schematic

