

PETOL™ HYDRA-TORK™ U4174 Operating Manual

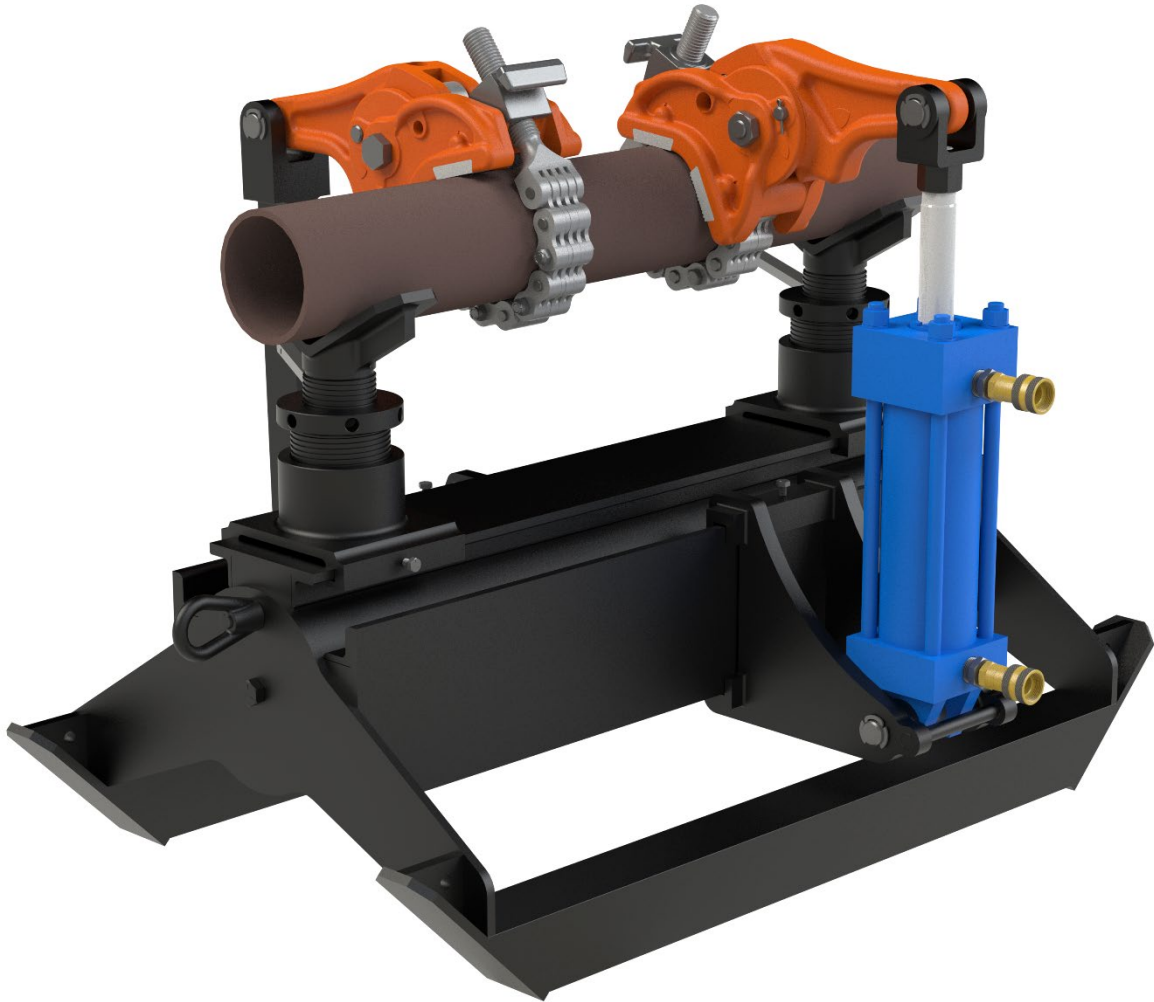

4450 S. Hwy. 6 | P.O. Box 192
Clifton, TX 76634 | USA
[www. PETOL.com](http://www.PETOL.com)

sales@petol.com | 254.675.8651

© 2022 by PETOL GEARENCH. All rights reserved

Form U4174 revision 03/18/2022

Table of Contents

PETOL™ U4174 HYDRA-TORK™ Description	3
Torque Rating	3
PETOL™ GEARENCH Limited Warranty	4
Safe Practices and Procedures.....	6
Responsibility	6
Replacement Parts	6
Safety	6
Safe Practices.....	7
Safety Precautions	8
Responsibility of Distributors.....	8
Tong Chain Inspection	9
Overloading / Shock Loads / Side Loading.....	9
Environmental Conditions	9
Normal Life Expectancy.....	10
Lubrication.....	10
Periodic Inspection List for PETOL™ Special Chain.....	11
Installation	12
Location	12
Dimensions	12
Setup	12
Operation	13
Controls	13
Torque – Pressure Conversion Formulas.....	13
Chain Selection.....	14
Chain Identification Guide	15
Tong Adjustment	16
Loading.....	16
Breaking Out.....	17
Making Up.....	17
Parts List.....	18
Final Assembly	19
Base Assembly	20
Cylinder Assembly	21
Backup Assembly	22
Vee Saddle Assembly	23
Tong Assembly.....	24
PETOL™ Special Chain Parts List	25
Wear Limits.....	26

PETOL™ U4174 HYDRA-TORK™ Description

The U4174 PETOL™ HYDRA-TORK™ unit was designed for making up and breaking out downhole tools. It is rated for operation on 3” to 8-1/4” diameters with a maximum working load of up to 17,500 ft-lbs depending upon diameter. See the table at the bottom of the page for specific torque ratings. The unit may be operated in any position (horizontal or inclined) and is totally portable.

The PETOL Drill Pipe Tongs are adjusted to the different diameters within their range by adjusting the chain screw nut for fine adjustment and by adding or removing sections of chain for the coarse adjustment.

The U4174 also offers the following features:

The tong cylinder and backup tong are mounted on independent tracks for adjusting and switching from make up to break out.

Two adjustable vee-saddles mounted on the hydra-tork base for support. The vee-saddles are also mounted on tracks for easy adjustment.

The unit can be operated with any commercially available hydraulic power unit capable of delivering 3000 psi pressure.

Torque Rating

The following working load limits should always be observed. Exceeding these limits could result in breaking the tong chain resulting in damage to equipment and possible injury to personnel.

Diameter	Max. Torque
3” – 4-5/8”	16,900 ft-lbs
4-3/4” – 5-7/8”	17,100 ft-lbs
6” – 6-7/8”	17,300 ft-lbs
7” – 8-1/4”	17,500 ft-lbs

PETOL™ GEARENCH Limited Warranty

What Is Covered

PETOL™ GEARENCH tools are expressly warranted to you, the purchaser, to be free of defects in material and workmanship.

How Long Coverage Lasts

This express warranty lasts for the lifetime of the PETOL GEARENCH tool. Warranty coverage ends when the tool becomes unusable for reasons other than defects in workmanship or material.

How Can You Get Warranty Service

To obtain the benefit of this warranty, contact a PETOL GEARENCH sales representative in Clifton, Texas.
PETOL GEARENCH · 4450 S. Highway 6 · P.O. Box 192 · Clifton, TX 76634

What Will We Do To Correct Problems

Warranted products will be repaired or replaced, at PETOL GEARENCH's option, and returned at no charge to you, the original purchaser; or, if after three attempts at repair or replacement during the warranty period, the product defect in material or workmanship persists, you can elect to receive a full refund of your original purchase price for the product.

What Is Not Covered

Defects, failures or conditions that are due to normal wear and tear, abuse or misuse, are not covered by this limited warranty. In addition, this limited warranty is in lieu of all other warranties, express or implied, verbal or written. To the maximum extent allowed by law PETOL GEARENCH disclaims all implied warranties, including implied warranties of merchantability and/or fitness for a particular purpose. PETOL GEARENCH also specifically denies any liability for any incidental damages and/or consequential damages, including but not limited to property damage to property other than the product itself, loss of sales profits, down time, costs or any other damages measurable in money, whether or not included in the foregoing enumeration.

Please be advised that some states do not allow the exclusion or limitation of incidental or consequential damages, so this limitation or exclusion may not apply to you. This warranty gives you specific rights, and you may also have other rights, which vary from state to state, province to province, or country to country.

Are Personal Injuries Covered

In the event you, someone working for you, or any other person sustain a personal injury as a result of using the PETOL GEARENCH tool, PETOL GEARENCH limits its potential liability for such a claim or injury to the fullest extent allowed by law, and disclaims and denies any liability for such personal injury.

Please be advised that some states do not allow the exclusion or limitation of liability for personal injuries, so the above limitation or exclusion may not apply to you, or the individual claiming injury.

No Other Express Warranty Applies

This PETOL GEARENCH LIMITED WARRANTY is the sole and exclusive warranty, express or implied for PETOL GEARENCH products. No employee, agent, dealer or other person is authorized to alter, modify, expand or reduce the terms of this warranty or to make any other warranty on behalf of PETOL GEARENCH.

Law Applicable

All matters related to the sale and/or use of the PETOL GEARENCH tool that is the subject of this limited warranty, along with the construction and enforcement of the terms of this limited warranty itself, shall be subject to the substantive and procedural laws of the state of Texas, not the conflicts of laws provisions of Texas, but rather the laws of Texas themselves.

Forum Selection Clause

Any dispute arising out of the sale and/or use of the PETOL GEARENCH tool that is the subject of this limited warranty shall be presented in the form of a claim or lawsuit to the offices of PETOL GEARENCH in Clifton, Bosque County, Texas. No claim or suit may be brought against PETOL GEARENCH, arising out of the sale and/or use of the tool, or arising out of the terms of this warranty, except in such forum. Purchase and/or use of the PETOL GEARENCH tool makes you subject to the benefits and limitations of this limited warranty. Accordingly, any writ, judgment or other enforcement, obtained from a jurisdiction, county, parish, state or federal court or other country, other than from the forum identified above, shall be void and unenforceable against PETOL GEARENCH.

Arbitration Clause

In the event of dispute or claim arises out of the sale and/or use of the PETOL GEARENCH tool that is the subject of this limited warranty, or arises out of the interpretation or enforcement of the terms and conditions of this limited warranty, such dispute shall be submitted to binding arbitration pursuant to the rules of the American Arbitration Association. If required to accomplish the purpose of this Arbitration clause, the purchaser hereby expressly waives any right to demand trial by jury.

Complete Agreement

This express limited warranty contains the entire agreement regarding express or implied warranties related to the PETOL GEARENCH tool that is the subject of it. No writing or language contained in the purchase order or any other document of the purchaser, or invoice of PETOL GEARENCH or any intermediate seller, shall be construed as modifying, in any way, the rights and liabilities contained in this limited warranty. PETOL GEARENCH expressly disclaims any obligations expressed in any customer purchase order or document that are contrary to the terms and limitations of this warranty.

Severability

If any term or limitation contained in this limited warranty is deemed unenforceable by law, then the term shall be severed from the remaining portions of the limited warranty which shall remain enforceable.

All communications to PETOL GEARENCH regarding the use of the tool and any aspect of the sale of the tool of this limited warranty should be addressed to PETOL GEARENCH.

PETOL GEARENCH · 4450 S. Highway 6 · P.O. Box 192 · Clifton, TX 76634

Safe Practices and Procedures

Responsibility

"It is the responsibility of the employer to train the employee in the proper selection and usage of tools, chains, etc., and to ensure that they are selected and used in that manner. In many instances, injury results because it is assumed that anybody knows how to use common hand tools. Observations and the record show that this is not the case. A part of every job instruction program should therefore be detailed training in the proper use of hand tools (and of all other special tools and equipment needed to accomplish the job)." - (Source: National Safety Council)

"Employers are responsible for the safe condition of tools and equipment used by employees, including tools and equipment which may be furnished by employees." - (Source: OSHA 1910.242A)

Replacement Parts

Use only PETOL™ replacement parts - no other parts are of comparable strength, quality and interchangeability.

Safety

While we pride ourselves on the quality and dependability that we build into PETOL™ GEARENCH tools and products, we caution users that it is only prudent to know and follow the simple rules of safety when using our products, or anyone else's.

Always follow safe practices and procedures in accordance with the recommendations of OSHA, The National Safety Council (NSC), The Hand Tools Institute (HTI), The International Association of Drilling Contractors (IADC), Etc. All applicable Governmental rules, regulations or restrictions, now in effect or which may be promulgated, take precedence over the suggestions in this publication. The information in this publication is designed to supplement standard safe practices and procedures, not in lieu of, or replacement thereof.

Safe Practices

(Source: The National Safety Council)

Failure to observe one or more of the following five safe practices accounts for most hand and powered tool accidents:

1. ALWAYS WEAR SAFETY GOGGLES TO PROTECT EYES
2. SELECT THE RIGHT TOOL FOR THE JOB
3. KEEP TOOLS IN GOOD CONDITION
4. USE TOOLS CORRECTLY
5. KEEP TOOLS IN A SAFE PLACE

Safety Goggles must always be worn by persons in any area where hand and powered tools are being used.

Never apply excess leverage to a wrench or tool by means of a "Cheater Bar". Never strike wrenches and tools with hammers or other objects.

All tools should be kept clean, inspected on a regular basis, and replaced when they show signs of wear.

Be especially careful not to place yourself in a position that could result in bodily injury in the event of a failure. See diagram on page 17.

READ SAFE PRACTICES AND PROCEDURES MANUAL, CATALOG INFORMATION AND PRODUCT LABELING PRIOR TO OPERATION.

Safety Precautions

1. Always wear safety goggles to protect eyes.
2. Select the right tool for the job.
3. Keep tools in good condition.
4. Use tools correctly.
5. Keep tools in a safe place.
6. Wear protective clothing, gloves and safety shoes as appropriate.
7. Use lengths of assembled chain. Do not build lengths from individual components.
8. Do not attempt to rework damaged chain by replacing only the components obviously faulty. The entire chain may be compromised and should be discarded.
9. Never electroplate assembled leaf chains or components. Plating will result in failure from hydrogen embrittlement.
10. Do not weld any chain or component. Welding spatter should never be allowed to come into contact with chain or components.
11. Leaf chains are manufactured exclusively from heat-treated steels and therefore must not be annealed. If heating a chain with a cutting torch is absolutely necessary for removal, the chain must not be reused.
12. Inspect chains frequently and regularly for link plate cracking, pin turning, pin protrusion and corrosion.
13. Use only PETOL™ replacement parts to ensure proper strength.

Responsibility of Distributors

IT IS THE RESPONSIBILITY OF THE PURCHASERS OF PETOL™ GEARENCH PRODUCTS TO CONVEY THE INFORMATION IN THIS PUBLICATION AND ANY OTHER INFORMATION RELATING TO THE INDIVIDUAL PRODUCT, THROUGH THE CHANNELS OF DISTRIBUTION, DOWN TO AND INCLUDING THE INDIVIDUAL USING THE PRODUCT

NOTE:

In view of the fact that the actual use determines whether safety requirements have been met, the ultimate responsibility to comply rests with the end user.

Tong Chain Inspection

The service life of leaf chains can be altered by a variety of adverse operating conditions. The following information discusses the most important of these conditions for consideration when operating or scheduling replacement of leaf chain systems.

Overloading / Shock Loads / Side Loading

Do not attempt to “inch loads which are beyond the rated capacity of the tool.

Do not strike the tool with a hammer or other object while force is being exerted in an attempt to loosen a “frozen” joint.

Side pull can be caused by pulling or pushing on the tong in a direction that is not along a perpendicular plane, unlevelled mounting of the tong or vise, inadequate support of the part being broken out, and improper seating of the part being broken out in the tong or vise. Improper seating will occur when the diameter of the part is not consistent within the width of the tong or vise jaw.

Environmental Conditions

Wrench chains operate in widely varying environments, from wet outdoor conditions to mildly or highly corrosive industrial atmospheres. They can also be exposed to abrasives such as sand or grit.

The possible effects include:

Moisture - Corrosion and rust reduce chain strength by causing pitting and cracking.

Temperature - Very cold temperatures reduce chain strength by embrittlement.

Chemical Solutions or Vapors - Corrosive attack of the chain components' grain structure and/or the mechanical connections between the chain components (crevice corrosion) may occur. Cracking often is microscopic. Propagation to complete failure can be eventual or sudden.

Abrasives - Accelerated wearing and scoring of the articulating chain members (pins and plates) may occur, with a corresponding reduction in chain strength. Due to inaccessibility of the bearing surfaces (pin surfaces and plate apertures), wear and scoring are not readily noticeable.

These conditions, when coupled with normal chain wear and inherent residual stress (normally in the chain as constructed), can result in environmentally assisted failure. It is impossible to predict chain life under complex conditions, as the degree of hostility and its effects are dependent on many variables such as temperature, time of exposure, concentration of corrosive atmosphere or medium, degree of abrasive wear, etc. Establishing the degree and frequency of unpredictable dynamic loading is also difficult.

Normal Life Expectancy

A leaf chain's normal life expectancy can be expressed as a maximum percent of elongation. This is generally between 2% and 3% of pitch. As the chain flexes back and forth, the bearing joints (pins and inside link plates) gradually wear from articulation. As with all steel bearing surfaces, the precision hardened steel joints of leaf chain require a constant film of oil between mating parts to prevent wear and to resist corrosion.

Lubrication

One of the most important but often overlooked factors is adequate lubrication. In addition to reducing internal friction, maintaining a film of oil on all chain surfaces will inhibit rusting and corrosion, this is important as corrosion of highly stressed, hardened steel chain components can cause a major reduction in the load capacity of leaf chain and result in link plate cracking.

Protection from corrosion is important in storage as well as in service. The factory lubricant applied to PETOL™ Chain is a "Fingerprint Neutralizing Water-Displacing Corrosion Preventative." This is an excellent rust and corrosion inhibitor for chains in storage.

Do not attempt to paint chains. Though painting may help inhibit corrosion, it will seal off critical clearances and restricts oil from reaching the pin surfaces where it is needed for good joint lubrication. Do not plate chains or chain components. Highly stressed alloy steel components are subject to hydrogen embrittlement caused by plating. Periodic relubrication of chains is the most important factor in extending the life of the chains. There is no lubricant that is ideal for all situations.

A heavy oil lubricant provides excellent protection during prolonged storage, but is messy to apply, will attract dirt and other contaminants and is messy to use. These contaminants could lead to premature abrasive wear of the moving components. When operating in dusty environments, lubricated chains will accumulate a paste like buildup of grime. At periodic intervals, this buildup should be removed by cleaning and the chain should be immediately relubricated. Do not use caustic or acid type cleaners; use a stiff brush and a certified safe petroleum base solvent.





Light oil-based lubricants penetrate into articulated joints easily but can also be washed off or rubbed off during use. A light oil-based lubricant must have periodic reapplication of the lubricant to maintain coverage.

Specialty chain lubricants (wax-based) provide excellent lubrication. They have no oily residue. They are easy to apply. They can be more expensive than other lubricants and are subject to being washed off or worn off. Wax-based lubricants must have periodic reapplication of the lubricant to maintain coverage.

The frequency of relubrication is the most important factor. It will depend on frequency of use, length of storage between uses, exposure to dust and other contaminants, and exposure to salt water or other corrosion accelerants. The end user should establish a good preventative maintenance program for relubrication of all chains and articulated components.

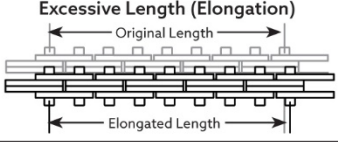
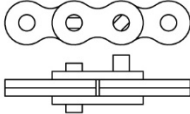
Periodic Inspection List for PETOL™ Special Chain

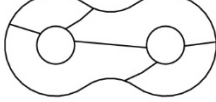
1. Prior to each use, Leaf Chain and tools should be inspected for serviceability and lubrication.
2. Use Only PETOL™ Replacement Parts - No other parts are of comparable strength, quality, and interchangeability.

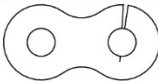
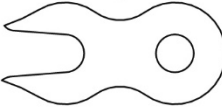
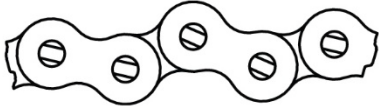
APPEARANCE AND/OR SYMPTOM	PROBABLE CAUSE	CORRECTION
<p>Excessive Length (Elongation)</p> 	<p>Normal Wear</p> <p>Permanent deformation (stretch) from overload</p>	<p>Replace chain</p> <p>Replace chain and correct cause of overload</p>
<p>Abnormal Protrusion of Pins</p> 	<p>Overloading</p> <p>Inadequate lubrication</p> <p>Side Loading</p>	<p>Replace chain and correct cause of overload</p> <p>Replace chain and improve lubrication</p> <p>Replace chain and correct cause of side load</p>
<p>Cracked Plates (Fatigue)</p> 	<p>Overloading</p> <p>Side Loading</p>	<p>Replace chain and correct cause of overload</p> <p>Replace chain and correct cause of side load</p>
<p>Arc-Like Cracked Plates (Stress Corrosion)</p> 	<p>Severe rusting or exposure to acidic or caustic medium, plus static stress at press fit between pin and plate.</p>	<p>Replace chain and protect from hostile environment</p>
<p>Enlarged Holes</p> 	<p>Overloading</p>	<p>Replace chain and correct cause of overload</p>
<p>Cracked Plates (Corrosion Fatigue) Perpendicular to Pitch Line, plus rust or other evidence of chemical corrosion</p> 	<p>Corrosive Environment</p>	<p>Replace chain and protect from hostile environment</p>
<p>Fractured Plates (Tension Mode)</p> 	<p>Overloading</p>	<p>Replace chain and correct cause of overload</p>
<p>Tight Joints</p> 	<p>Dirt or foreign substance packed in joints</p> <p>Corrosion and rust</p> <p>Bent Pins</p>	<p>Clean and relube</p> <p>Replace chain and protect from hostile environment</p> <p>Replace chain</p>

Installation

Location

The PETOL™ HYDRA-TORK™ Unit should be located in an area with adequate room to work the downhole tools. The unit may be located indoors or outdoors upon solid ground or a finished shop floor. No special foundation is required.

Dimensions

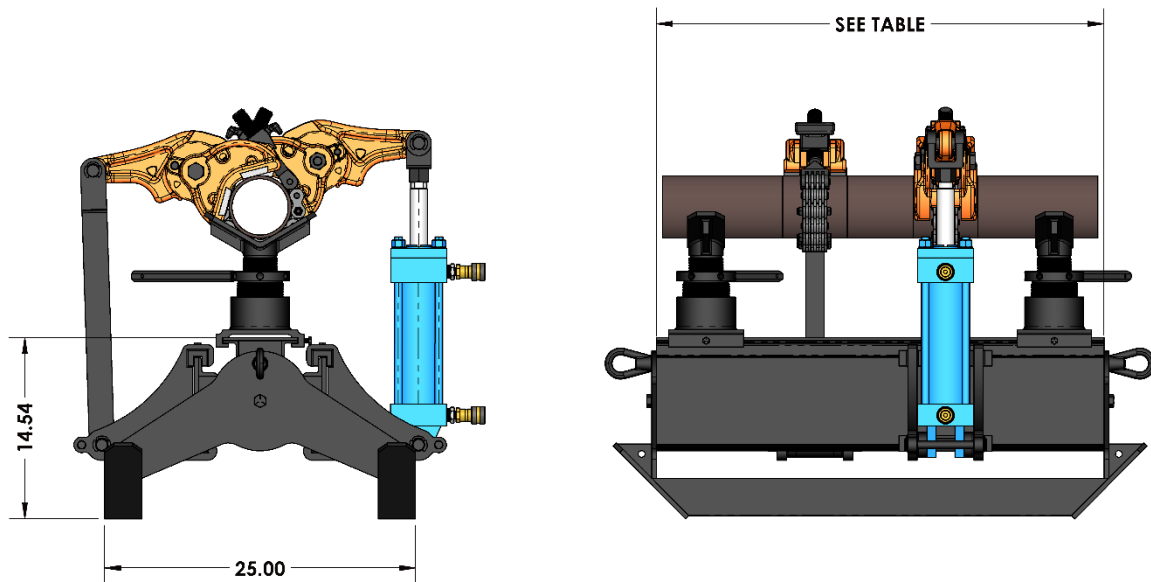

Part Number	Length (in)
U4174	36.00
U4174L	60.00

Setup

Locate the hydraulic power unit in a convenient location and connect the hoses to the hydraulic cylinder.

Operation

Controls

Use a hydraulic pressure gauge on the power unit to indicate the system pressure in psi. The torque produced by the PETOL™ Drill Pipe Tongs is dependent on the hydraulic pressure and the diameter. See Torque-Pressure Conversion Formulas below for conversion formulas equating the hydraulic pressure in psi to the torque output in foot-pounds.

WARNING: Never operate the tong with a pressure higher than required to perform the make up or break out operation. Operation at excessive pressure may damage the downhole tool and/or injure personnel.

Torque – Pressure Conversion Formulas

The following formula is used to determine the hydraulic pressure required to produce a known torque:

$$P = T / (0.232 * D + 6.465)$$

Where P is the pressure required in psi, T is the desired torque in foot-pounds and, D is the diameter at the tong with the cylinder attached in inches. To find the torque produced from an observed hydraulic pressure, use the following formula:

$$T = P * (0.232 * D + 6.465)$$

Where P is the pressure required in psi, T is the produced torque in foot-pounds and, D is the diameter at the tong with the cylinder attached in inches.

Chain Selection

The following table indicates the chains required for various diameters. The chains are selected by adding or subtracting sections of chain.

Chain Part Number	Diameter Range
151-45-07D	3 – 3 3/4
151-45-09D	3 3/4 – 4 1/2
151-45-11D	4 1/2 – 5 3/8
151-45-13D	5 3/8 – 6 1/4
151-45-15D	6 1/4 – 7
151-45-17D	7 1/16 – 8 1/4

Warning: Wrong chain selection could result in failure. See chain selection table above and chain identification guide on the following page.

Chain Identification Guide

2 LINK SECTION

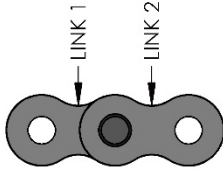

5 LINK SECTION

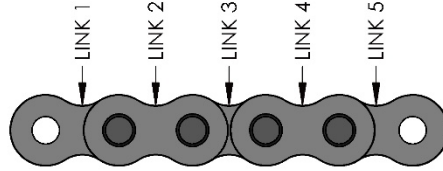

CHAIN ASSEMBLY

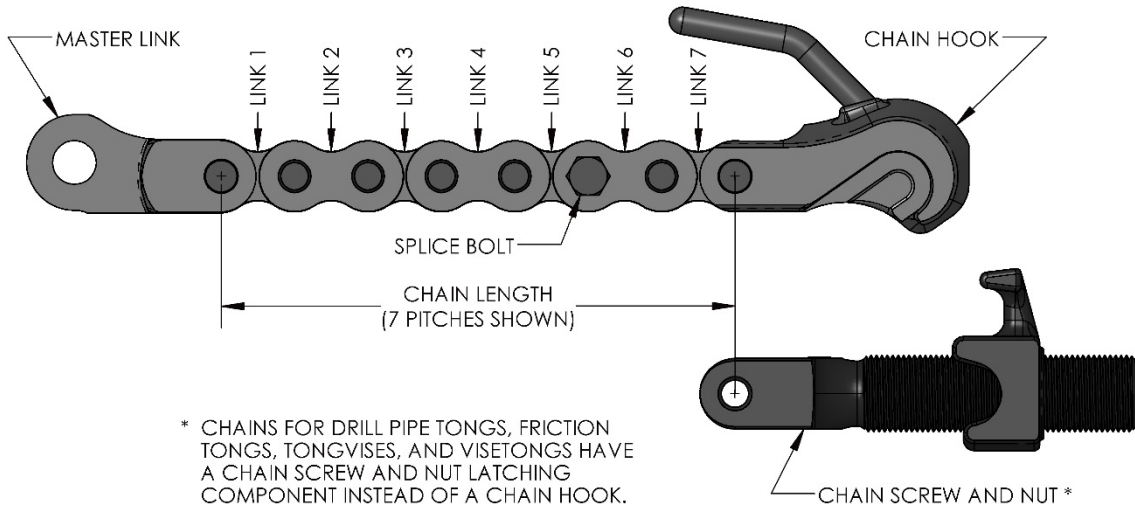

THIS IS WHAT A CHAIN PART NUMBER TELLS YOU

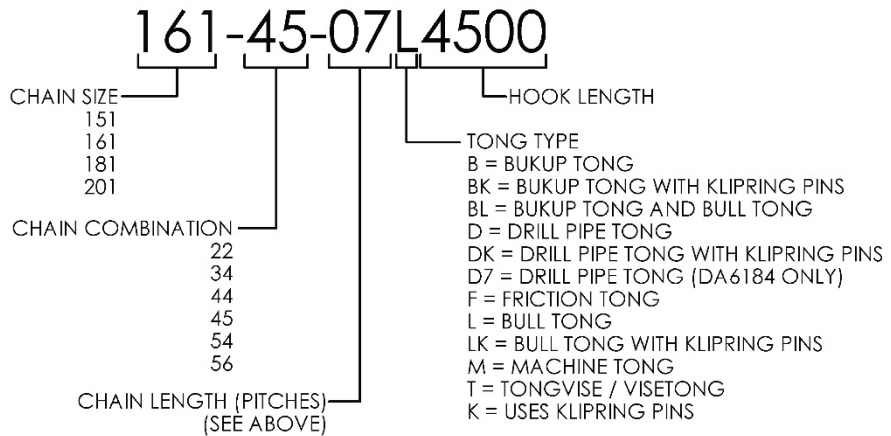

Tong Adjustment

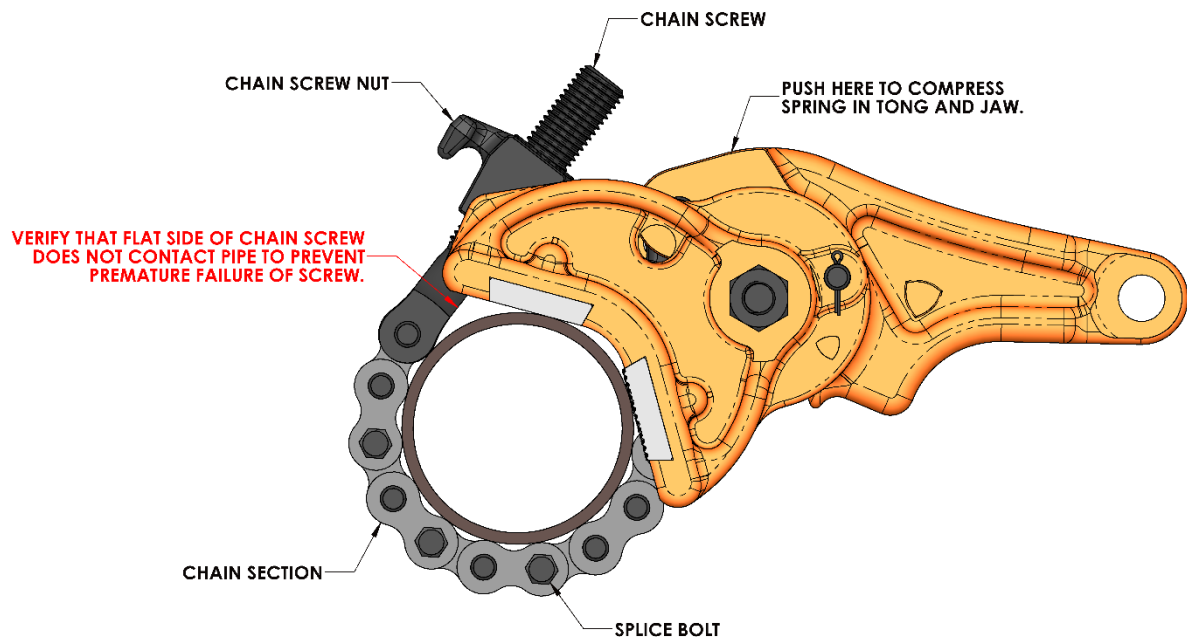

Warning! The pipe must **NOT** contact the flat side of the chain screw as shown above. Improper contact will cause premature breakage of the chain screw and could cause injury or death. If the flat side of the chain screw contacts the pipe, the chain **MUST** be lengthened by adding 2 pitches of chain.

Add or remove chain sections as needed using the splice bolts in the chains. Push on the top of the jaw to fully compress the spring inside the jaw. Adjust the chain screw nut so that the chain is as tight as possible and fit into the lugs in the jaw.

Loading

To load the downhole tool in the unit, adjust the vee-saddles to support the tool. Set the tool into the unit. Position the tongs for make up or break out as needed and set the tongs onto the tool. Adjust the tongs as described and latch the tong chains.

CAUTION: *The vee-saddles must be used to support the tool while torquing.*

Breaking Out

Load the tool and adjust the tongs as described above. Fully ratchet the tong by extending the cylinder. Set the system pressure to a minimum. Retract the cylinder. When the tong stops, begin increasing the system pressure. Keep increasing the system pressure until the connection is broken loose **or the working load of the tong is reached. Do not exceed the rating of the tong. Consult with PETOL™ GEARENCH as needed for help with the toughest break out jobs.** After the initial break out, ratchet the tong fully and then alternately extend and retract the cylinder until the connection is fully loosened.

Making Up

Load the tool and adjust the tong and vise as described above. Make up the connection hand tight using PETOL™-TITAN™ Chain Tongs. Preset the system pressure to obtain the desired torque if possible. Retract the cylinder. If the cylinder fully retracts without stalling, cycle the tong (extend / retract). Continue until the cylinder stalls or until the desired pressure is obtained.

Warning: Do not stand in line with the tongs or chains during operation.

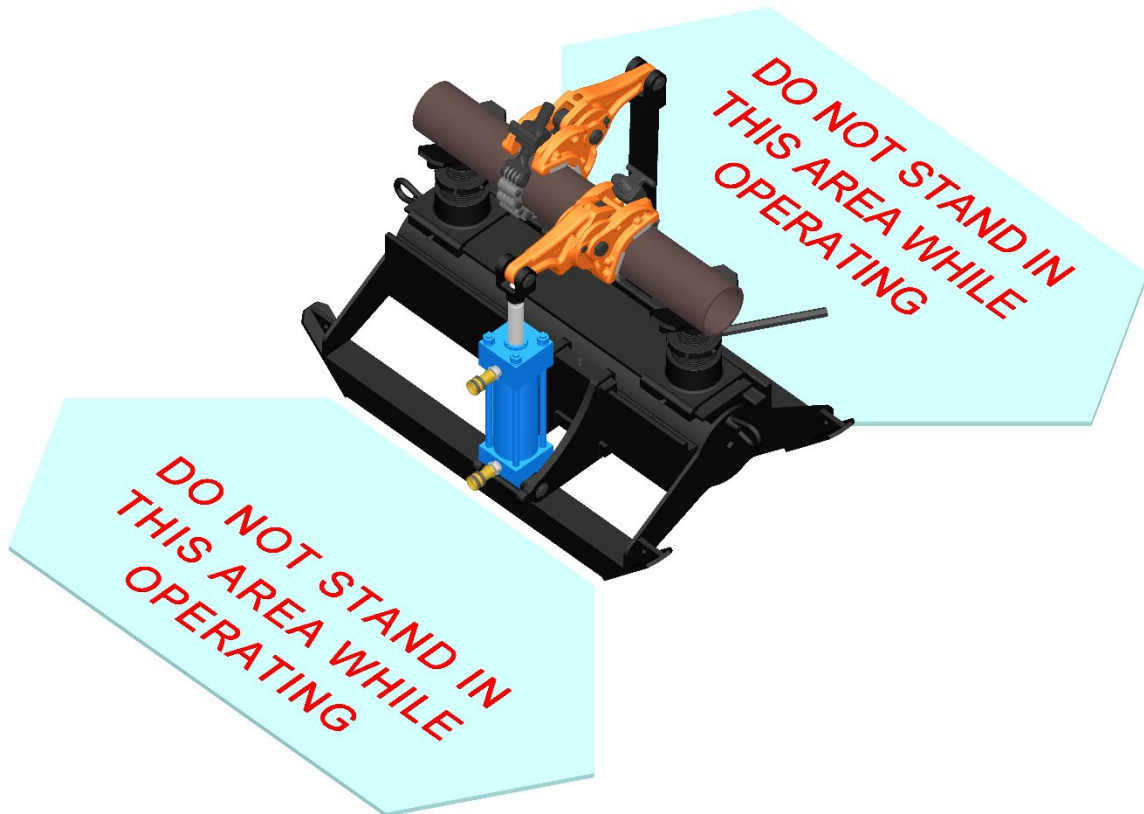

Parts List

The following drawings, diagrams, and parts lists describe all parts which may be needed as replacement items. Where appropriate, standard industrial and hydraulic components have been used. Should a standard industrial item need replacing, the item may be purchased locally. To assist you in obtaining parts, the OEM component manufacturer and model numbers are shown on the parts list. Of course, all replacement parts will be supplied by PETOL™ GEARENCH if you prefer to order from us.

All tong, vise, and chain components are manufactured only by PETOL GEARENCH. DO NOT ATTEMPT TO SUBSTITUTE THESE COMPONENTS. The unit will not work properly unless these components are matched to the specific application. Consult our factory as your requirement changes. Any non-PETOL GEARENCH substitutions of these components void all warranties and subject the user to assumption of liabilities resulting from subsequent use.

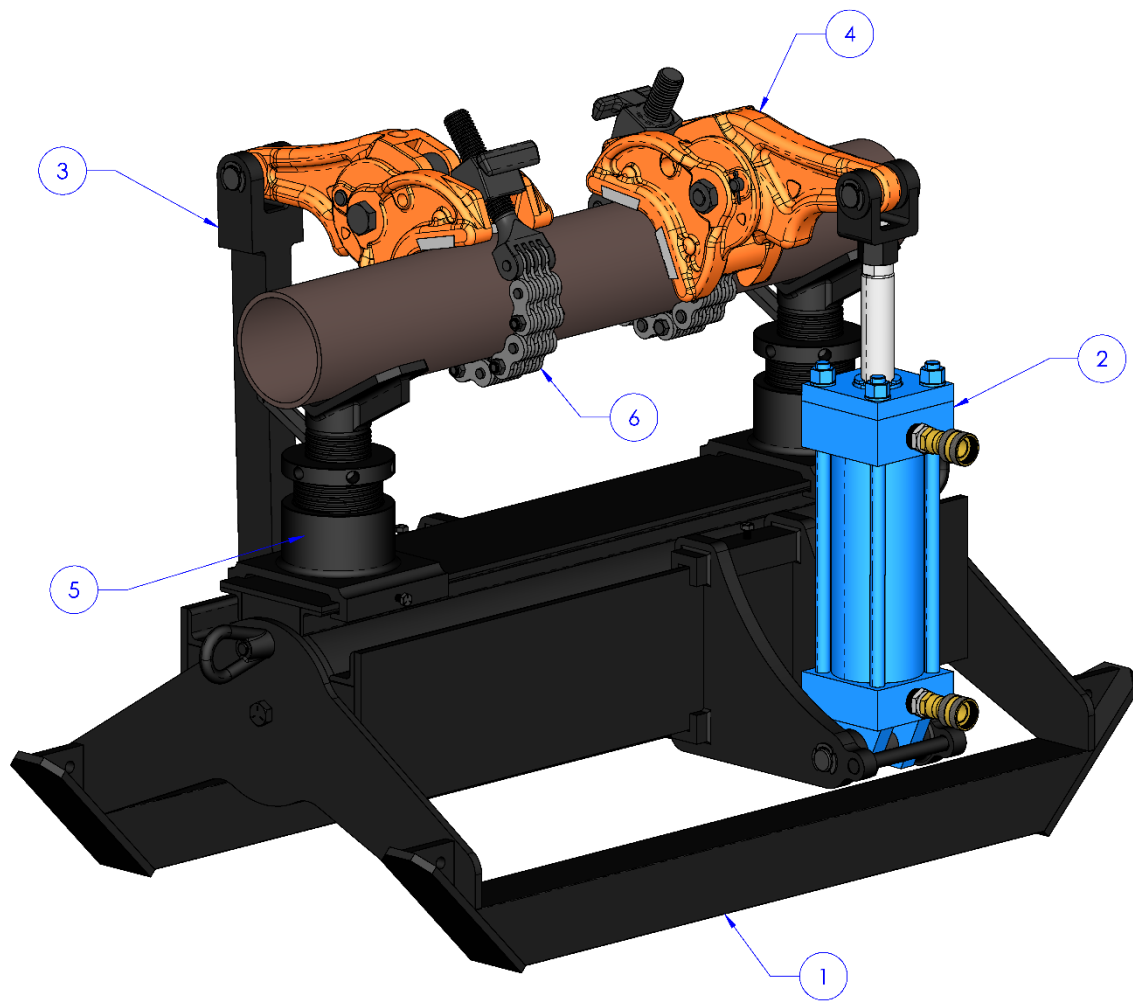

Final Assembly

Item	Qty	Part Number	Description	Notes
1	1	UB4174	Base assembly	U4174 only, see page 20
1	1	UB4174L	Base assembly	U4174L only, see page 20
2	1	UC4174	Cylinder assembly	See page 21
3	1	UK4174	Backup assembly	See page 22
4	2	DA4174-L08	Drill pipe tong assembly	See page 24
5	2	UHVSA-4174	Vee saddle assembly	See page 23
6	2	151-45-17D	Chain assembly	See page 25
7	4	HI04D	Diamond point insert (not shown)	Replace blank inserts for extra grip on small diameters

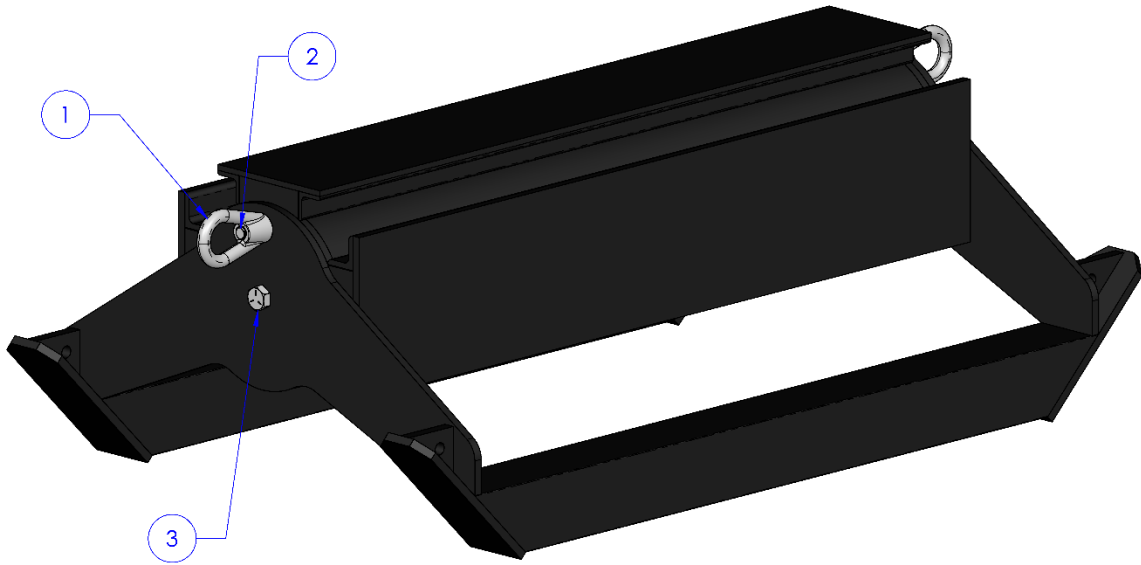

Base Assembly

Item	Qty	Part Number	Description	Notes
1	2	HXN049	Eye nut	McMaster-Carr 3274T43 (or equal)
2	2	HXS028	Stud	5/8-11UNC x 2-3/4" long
3	2	HXS029	Hex bolt	5/8-11UNC x 1-1/2" long

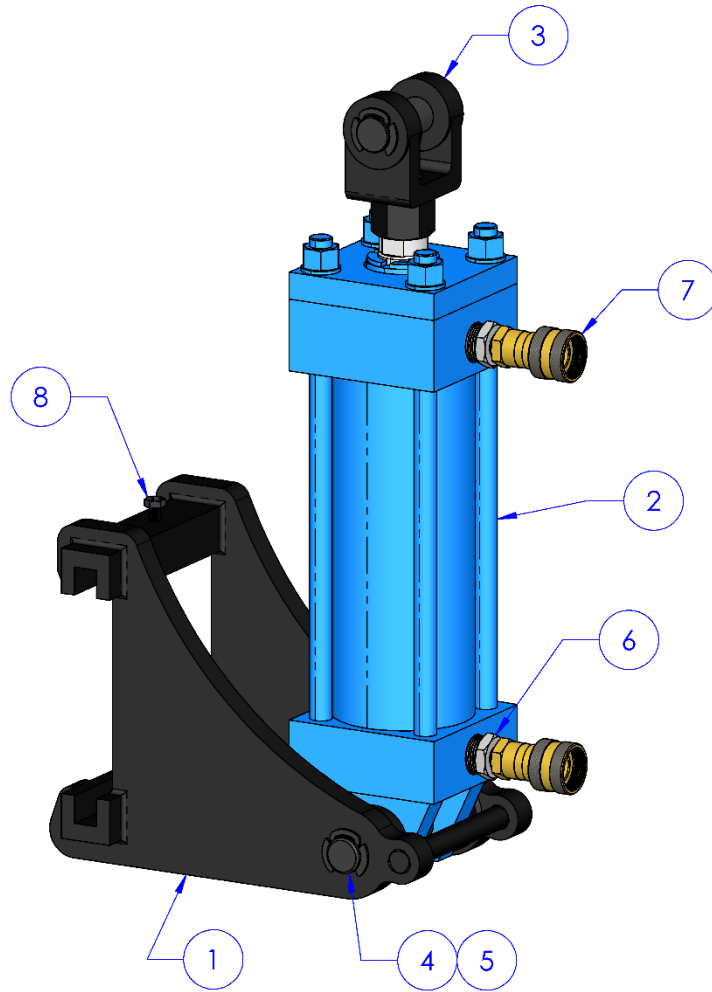

Cylinder Assembly

Item	Qty	Part Number	Description	Notes
1	1	UC4174-A	Arm assembly	
2	1	UC4174-C	Cylinder	Vickers/Aeroquip NZ10GH5N1KA08000
3	1	UC4174-E	Rod clevis	Vickers/Aeroquip S-662-10
4	1	HP372	Cylinder – arm pin	
5	2	HXKR100	Klipring	Waldes-Truarc 5304-100 (or equal)
6	2	UHCH-F41	Reducer bushing 3/4 x 3/8	Weatherhead C3109X12X6 (or equal)
7	2	UHCH-Q05	Quick coupler	Enerpac CR-400 (or equal)
8	1	HXS012	Hex bolt	5/16-18UNC x 7/8" long

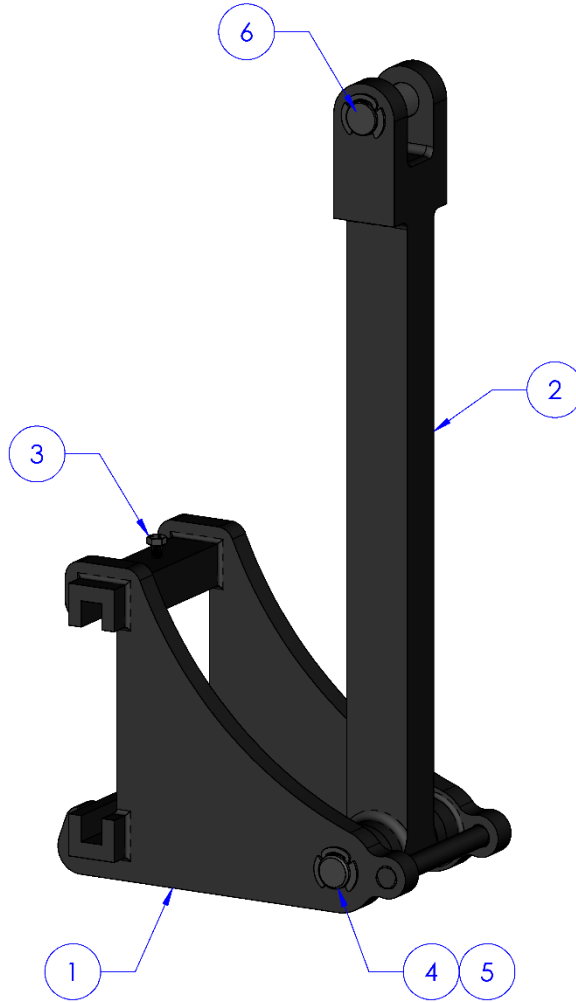

Backup Assembly

Item	Qty	Part Number	Description	Notes
1	1	UC4174-A	Arm assembly	
2	1	U4174-LK	Link arm	
3	1	HXS012	Hex bolt	5/16-18UNC x 7/8" long
4	1	HP372	Link – arm pin	
5	2	HXKR100	Klipring	Waldes-Truarc 5304-100 (or equal)
6	1	N/A	Link – handle pin	Use cylinder clevis pin from part number UC4174-C

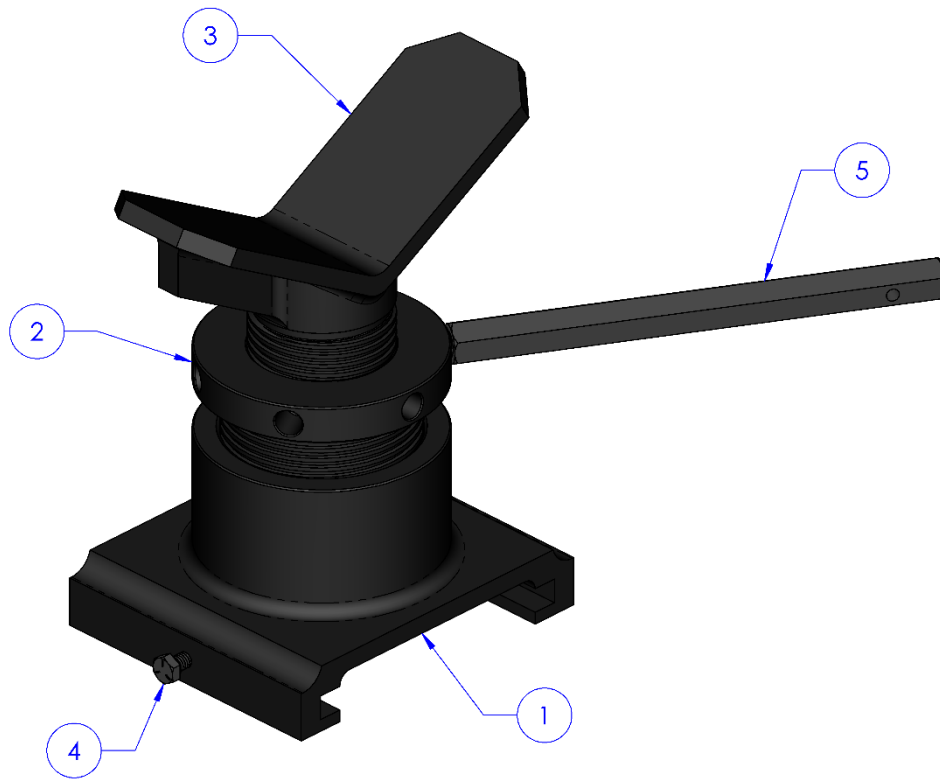

Vee Saddle Assembly

Item	Qty	Part Number	Description	Notes
1	1	UHVSB-4174	Base	
2	1	UHVSN-4174	Nut	
3	1	UHVSH-115H	Head	
4	1	HXS012	Hex bolt	5/16-18UNC x 7/8
5	1	HP951	Nut lever	

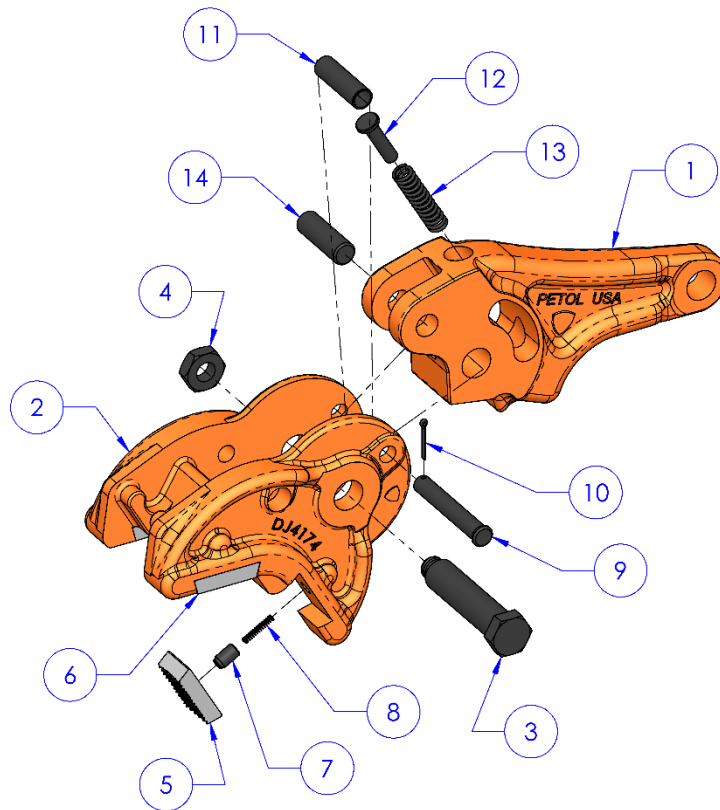

Tong Assembly

Item	Qty	Part Number	Description	Notes
1	1	DH4174-L08	Handle	
2	1	DJ4174	Jaw	
3	1	HB35	Jaw – handle bolt	
4	1	HXN003	Jaw bolt nut	
5	2	HI04D	Diamond point insert	Standard
5a	2	HI04K	Knurled insert	Optional (by order)
6	2	HI04B	Blank insert	Standard (Dia. > 3.75 in)
6a	2	HI04D	Diamond point insert	Optional (included, see page 19)
6b	2	HI04K	Knurled insert	Optional (by order)
7	4	HP903	Insert key	
8	4	HS20S	Insert key spring	
9	1	HP238	Spring pin	
10	1	HXC002	Spring pin cotter	
11	1	HU40	Spring pin bushing	
12	1	HG13	Spring guide	
13	1	HS19	Spring	
14	1	HP235	Master link – handle pin	

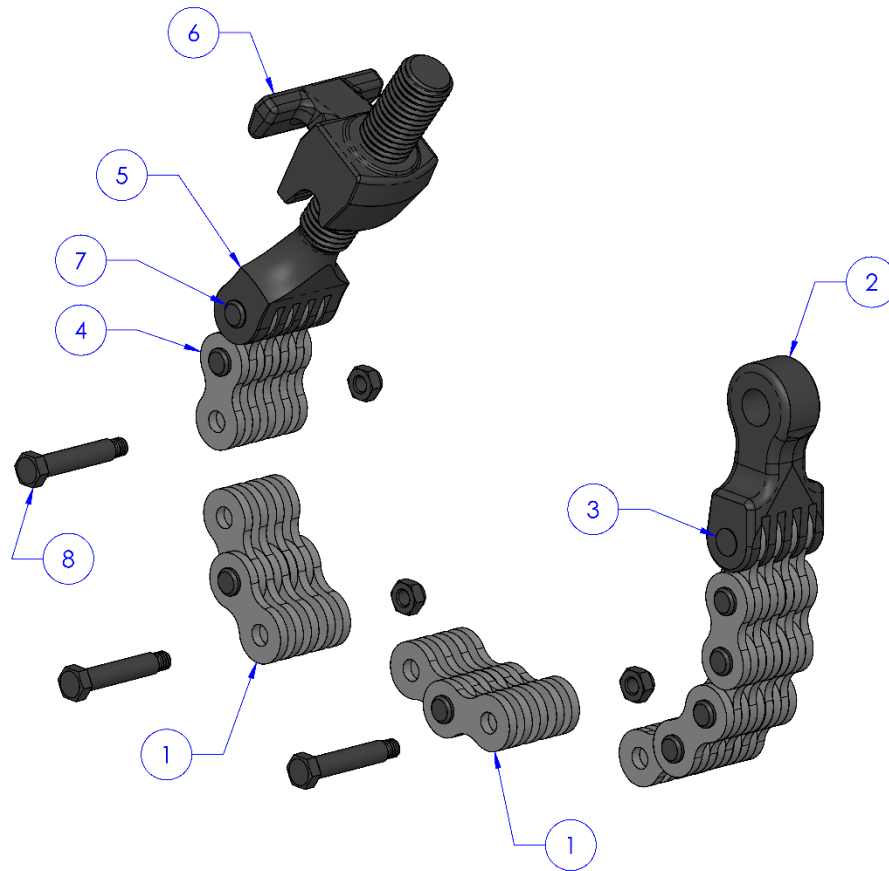

PETOL™ Special Chain Parts List

Item	Qty	Part Number	Description	Notes
1	As req'd	151-45-02	Special chain only	
1	As req'd	151-45-04	Special chain only	
1	As req'd	151-45-05	Special chain only	
2	1	HM01-45	Master link	
3	1	HP237	Master link – chain pin	
4	As req'd	151-45-02-HV02	Chain screw assembly	
5	1	HV02-45	Chain screw only	
6	1	HN01	Chain screw nut only	
7	1	HP236	Chain screw – chain pin	
8	As req'd	HB48	Splice bolt and nut	
8	As req'd	HXN015	Splice bolt nut only	

Wear Limits

The following table indicates limiting diameters on the components of the PETOL™ Drill Pipe Tong. When localized wear is beyond any one of the limits indicated, the component should be replaced.

Part Number	Description	Location	Limit Dimension [in]
HB35	Jaw – handle bolt	Bolt body diameter	0.980 (min)
HP235	Master link – handle pin	Pin body diameter	0.734 (min)
HB48	Chain splice bolts	Bolt body diameter	0.427 (min)
151-45-XX	Chain links	Pin hole diameter	0.451 (max)
151-45-XX	Chain links	Pitch center – center	1.287 (max per pitch)
DH4174-L08	Handle	Jaw pin hole diameter	1.025 (max)
DH4174-L08	Handle	Chain pin hole diameter (master link)	0.769 (max)
DH4174-L08	Handle	Load loop diameter	1.031 (max)
DJ4174	Jaw	Jaw pin hole diameter	1.025 (max)
HM01-45	Master link	Handle pin hole diameter	0.769 (max)
HM01-45	Master link	Chain pin hole diameter	0.451 (max)
HV02-45	Chain screw	Chain pin hole diameter	0.451 (max)