

PETOL™ PULLDOWN VISETONGS

Operating Manual

PETOL™ GEARENCH

P.O. Box 192

4450 South Highway 6

Clifton, Texas 76634

Phone: (254) 675-8651

Fax: (254) 675-6100

© 2020 by PETOL™ GEARENCH. All rights reserved

Form VTDA revision 06/15/2020

Table of Contents

PETOL™ PULLDOWN VISETONGS Description	1
PETOL™ GEARENCH Limited Warranty	2
Safe Practices and Procedures	4
Responsibility	4
Replacement Parts	4
Safety	4
Safe Practices	5
Responsibility of Distributors.....	5
Chain Inspection	6
Overloading / Shock Loads / Side Loading	6
Environmental Conditions	6
Normal Life Expectancy.....	7
Lubrication	7
Periodic Inspection List for Petol Special Chain	8
Tong Inspection	11
Inspection Wear Limits	12
Safety Precautions	13
Operation	14
Pawl Operation	15
Torque Capacity	16
Parts Lists	17
VTDA115H Parts List	18
VTDA116H Parts List	19
VTDA118 Parts List.....	20
VTDA120 Parts List.....	21
Chain Assembly Parts Lists	22
Chain Selection.....	24

PETOL™ PULLDOWN VISETONGS Description

The PETOL™ Pulldown Visetongs were designed for making up and breaking out tool joints, drill collars, reamers, and similar heavy jobs requiring substantial torque. A hydraulic cylinder can be attached to the end of the tong handle.

The tongs are easily adjusted to various pipe sizes by simply sliding the heat-treated PETOL Special Chain through the jaw of the tong and engaging the locking cam lever.

The PETOL Pulldown Visetongs offer the following features:

A high strength, heat-treated alloy chain for rugged, dependable service.

High strength alloy steels used throughout for long life with the toughest jobs.

Regardless of the load on the handle, these tongs will not jam.

The tongs have a minimum crushing effect and a great strength for their weight.

These tongs are equipped with replaceable high-speed steel PETOL Diamond Point Inserts, which minimize marring of pipe surfaces.

PETOL™ GEARENCH Limited Warranty

What Is Covered

PETOL™ GEARENCH tools are expressly warranted to you, the purchaser, to be free of defects in material and workmanship.

How Long Coverage Lasts

This express warranty lasts for the lifetime of the PETOL GEARENCH tool. Warranty coverage ends when the tool becomes unusable for reasons other than defects in workmanship or material.

How Can You Get Warranty Service

To obtain the benefit of this warranty, contact a PETOL GEARENCH sales representative in Clifton, Texas.

PETOL GEARENCH · 4450 South Highway 6 · P.O. Box 192 · Clifton, TX 76634

What We Will Do To Correct Problems

Warranted products will be repaired or replaced, at PETOL GEARENCH's option, and returned at no charge to you, the original purchaser; or, if after three attempts at repair or replacement during the warranty period, the product defect in material or workmanship persists, you can elect to receive a full refund of your original purchase price for the product.

What Is Not Covered

Defects, failures or conditions that are due to normal wear and tear, abuse or misuse, are not covered by this limited warranty. In addition, this limited warranty is in lieu of all other warranties, express or implied, verbal or written. To the maximum extent allowed by law PETOL GEARENCH disclaims all implied warranties, including implied warranties of merchantability and/or fitness for a particular purpose. PETOL GEARENCH also specifically denies any liability for any incidental damages and/or consequential damages, including but not limited to property damage to property other than the product itself, loss of sales profits, down time, costs or any other damages measurable in money, whether or not included in the foregoing enumeration.

Please be advised that some states do not allow the exclusion or limitation of incidental or consequential damages, so this limitation or exclusion may not apply to you. This warranty gives you specific rights, and you may also have other rights, which vary from state to state, province to province, or country to country.

Are Personal Injuries Covered

In the event you, someone working for you, or any other person sustain a personal injury as a result of using the PETOL GEARENCH tool, PETOL GEARENCH limits its potential liability for such a claim or injury to the fullest extent allowed by law, and disclaims and denies any liability for such personal injury.

Please be advised that some states do not allow the exclusion or limitation of liability for personal injuries, so the above limitation or exclusion may not apply to you, or the individual claiming injury.

No Other Express Warranty Applies

This PETOL GEARENCH LIMITED WARRANTY is the sole and exclusive warranty, express or implied for PETOL GEARENCH products. No employee, agent, dealer or other person is authorized to alter, modify, expand or reduce the terms of this warranty or to make any other warranty on behalf of PETOL GEARENCH.

Law Applicable

All matters related to the sale and/or use of the PETOL GEARENCH tool that is the subject of this limited warranty, along with the construction and enforcement of the terms of this limited warranty itself, shall be subject to the substantive and procedural laws of the state of Texas, not the conflicts of laws provisions of Texas, but rather the laws of Texas themselves.

Forum Selection Clause

Any dispute arising out of the sale and/or use of the PETOL GEARENCH tool that is the subject of this limited warranty shall be presented in the form of a claim or lawsuit to the offices of PETOL GEARENCH in Clifton, Bosque County, Texas. No claim or suit may be brought against PETOL GEARENCH, arising out of the sale and/or use of the tool, or arising out of the terms of this warranty, except in such forum. Purchase and/or use of the PETOL GEARENCH tool makes you subject to the benefits and limitations of this limited warranty. Accordingly, any writ, judgment or other enforcement, obtained from a jurisdiction, county, parish, state or federal court or other country, other than that from the forum identified above, shall be void and unenforceable against PETOL GEARENCH.

Arbitration Clause

In the event of dispute or claim arises out of the sale and/or use of the PETOL GEARENCH tool that is the subject of this limited warranty, or arises out of the interpretation or enforcement of the terms and conditions of this limited warranty, such dispute shall be submitted to binding arbitration pursuant to the rules of the American Arbitration Association. If required to accomplish the purpose of this Arbitration clause, the purchaser hereby expressly waives any right to demand trial by jury.

Complete Agreement

This express limited warranty contains the entire agreement regarding express or implied warranties related to the PETOL GEARENCH tool that is the subject of it. No writing or language contained in the purchase order or any other document of the purchaser, or invoice of PETOL GEARENCH or any intermediate seller, shall be construed as modifying, in any way, the rights and liabilities contained in this limited warranty. PETOL GEARENCH expressly disclaims any obligations expressed in any customer purchase order or document that are contrary to the terms and limitations of this warranty.

Severability

If any term or limitation contained in this limited warranty is deemed unenforceable by law, then the term shall be severed from the remaining portions of the limited warranty which shall remain enforceable.

All communications to PETOL GEARENCH regarding the use of the tool and any aspect of the sale of the tool of this limited warranty should be addressed to PETOL GEARENCH.

PETOL GEARENCH · 4450 South Highway 6 · P.O. Box 192 · Clifton, TX 76634

Safe Practices and Procedures

Responsibility

“It is the responsibility of the employer to train the employee in the proper selection and usage of tools, chains, etc., and to ensure that they are selected and used in that manner. In many instances, injury results because it is assumed that anybody knows how to use common hand tools. Observations and the record show that this is not the case. A part of every job instruction program should therefore be detailed training in the proper use of hand tools (and of all other special tools and equipment needed to accomplish the job).” - (Source: National Safety Council)

“Employers are responsible for the safe condition of tools and equipment used by employees, including tools and equipment which may be furnished by employees.” - (Source: OSHA 1910.242A)

Replacement Parts

Use only PETOL™ & TITAN™ replacement parts - no other parts are of comparable strength, quality and interchangeability.

Safety

While we pride ourselves on the quality and dependability we build into PETOL™ GEARENCH tools and products, we caution users that it is only prudent to know and follow the simple rules of safety when using our products, or anyone else's.

Always follow safe practices and procedures in accordance with the recommendations of OSHA, The National Safety Council (NSC), The Hand Tools Institute (HTI), The National Association of Chain Manufacturers (NACM), The International Association of Drilling Contractors (IADC), Etc. All applicable Governmental rules, regulations or restrictions, now in effect or which may be promulgated, take precedence over the suggestions in this publication. The information in this publication is designed to supplement standard safe practices and procedures, not in lieu of, or replacement thereof.

Safe Practices

Failure to observe one or more of the following five safe practices accounts for most hand and powered tool accidents:

1. ALWAYS WEAR SAFETY GOGGLES TO PROTECT EYES
2. SELECT THE RIGHT TOOL FOR THE JOB
3. KEEP TOOLS IN GOOD CONDITION
4. USE TOOLS CORRECTLY
5. KEEP TOOLS IN A SAFE PLACE

Persons in any area where hand or powered tools are being used must always wear safety goggles.

Never strike wrenches and tools with hammers or other objects.

All tools should be kept clean, inspected on a regular basis, and replaced when they show signs of wear.

Be especially careful not to place yourself in a position that could result in bodily injury in the event of a failure. See diagram on page 20.

READ SAFE PRACTICES AND PROCEDURES MANUAL, CATALOG INFORMATION, AND PRODUCT LABELING PRIOR TO OPERATION.

Responsibility of Distributors

IT IS THE RESPONSIBILITY OF THE PURCHASERS OF PETOL GEARENCH PRODUCTS TO CONVEY THE INFORMATION IN THIS PUBLICATION AND ANY OTHER INFORMATION RELATING TO THE INDIVIDUAL PRODUCT, THROUGH THE CHANNELS OF DISTRIBUTION, DOWN TO AND INCLUDING THE INDIVIDUAL USING THE PRODUCT

NOTE:

In view of the fact that the actual use determines whether safety requirements have been met, the ultimate responsibility to comply rests with the end user.

Chain Inspection

The service life of leaf chains can be altered by a variety of adverse operating conditions. The following information discusses the most important of these conditions for consideration when operating or scheduling replacement of leaf chain systems.

Overloading / Shock Loads / Side Loading

Attempting to “inch loads which are beyond the rated capacity of the tool.

Striking the tool with a hammer or other object while force is being exerted in an attempt to loosen a “frozen” joint.

Side pull can be caused by pulling or pushing on the tong in a direction that is not along a perpendicular plane, unlevelled mounting of the tong or vise, inadequate support of the part being broken out, and improper seating of the part being broken out in the tong or vise. Improper seating will occur when the diameter of the part is not consistent within the width of the tong or vise jaw.

Environmental Conditions

Wrench chains operate in widely varying environments, from wet outdoor conditions to mildly or highly corrosive industrial atmospheres. They can also be exposed to abrasives such as sand or grit.

The possible effects include:

Moisture - Corrosion and rust reduce chain strength by causing pitting and cracking.

Temperature - Very cold temperatures reduce chain strength by embrittlement.

Chemical Solutions or Vapors - Corrosive attack of the chain components’ grain structure and/or the mechanical connections between the chain components (crevice corrosion) may occur. Cracking often is microscopic. Propagation to complete failure can be eventual or sudden.

Abrasives - Accelerated wearing and scoring of the articulating chain members (pins and plates) may occur, with a corresponding reduction in chain strength. Due to inaccessibility of the bearing surfaces (pin surfaces and plate apertures), wear and scoring are not readily noticeable.

These conditions, when coupled with normal chain wear and inherent residual stress (normally in the chain as constructed); can result in environmentally assisted failure. It is impossible to predict chain life under complex conditions, as the degree of hostility and its effects are dependent on many variables such as temperature, time of exposure, concentration of corrosive atmosphere or medium, degree of abrasive wear, etc. Establishing the degree and frequency of unpredictable dynamic loading is also difficult.

Normal Life Expectancy

A leaf chain's normal life expectancy can be expressed as a maximum percent of elongation. This is generally between 2% and 3% of pitch. As the chain flexes back and forth, the bearing joints (pins and inside link plates) gradually wear from articulation. As with all steel bearing surfaces, the precision hardened steel joints of leaf chain require a constant film of oil between mating parts to prevent wear and to resist corrosion.

Lubrication







One of the most important but often overlooked factors is adequate lubrication. In addition to reducing internal friction, maintaining a film of oil on all chain surfaces will inhibit rusting and corrosion, this is important as corrosion of highly stressed, hardened steel chain components can cause a major reduction in the load capacity of leaf chain and result in link plate cracking.

Protection from corrosion is important in storage as well as in service. The factory lubricant applied to PETOL™ Chain is a "Fingerprint Neutralizing Water-Displacing Corrosion Preventative". This is an excellent rust and corrosion inhibitor for chains in storage. When installing these chains new, do not attempt to steam clean or degrease this lubricant. A grade of SAE 30 or 40 weight, non-detergent motor oil should be used as supplemental lubricant and a film of this oil should be maintained on all surfaces and internal bearing joints. Also, do not attempt to paint new chains. Though painting may help inhibit corrosion, it will seal off critical clearances and restricts oil from reaching the pin surfaces where it is needed for good joint lubrication.

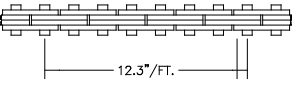
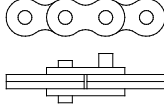
When operating in dusty environments, lubricated chains will accumulate a paste-like buildup of grime. At periodic intervals, this buildup should be removed by cleaning and the chain should be immediately re-lubricated. Do not use caustic or acid type cleaners; use a stiff brush and a certified safe petroleum base solvent.

Periodic Inspection List for Petol Special Chain

1. PRIOR TO EACH USE, LEAF CHAIN AND TOOLS SHOULD BE INSPECTED FOR SERVICEABILITY AND LUBRICATION.
2. USE ONLY PETOL™ AND TITAN™ REPLACEMENT PARTS - NO OTHER PARTS ARE OF COMPARABLE STRENGTH, QUALITY, AND INTERCHANGEABILITY.

APPEARANCE AND/OR SYMPTOM	PROBABLE CAUSE	CORRECTION
<p>Excessive Length (Elongation)</p> 	<p>Normal wear</p> <p>Permanent deformation (stretch) from overload</p>	<p>Replace chain</p> <p>Replace chain and correct cause of overload</p>
<p>Abnormal Protrusion of Pins</p> 	<p>Overloading</p> <p>Inadequate lubrication</p> <p>Side loading</p>	<p>Replace chain and correct cause of overload</p> <p>Replace chain and improve lubrication</p> <p>Replace chain and correct cause of side load</p>
<p>Cracked Plates (Fatigue)</p> 	<p>Overloading</p> <p>Side loading</p>	<p>Replace chain and correct cause of overload</p> <p>Replace chain and correct cause of side load</p>
<p>Arc-Like Cracked Plates (Stress Corrosion)</p> 	<p>Severe rusting or exposure to acidic or caustic medium, plus static stress at press fit between pin and plate</p>	<p>Replace chain and protect from hostile environment</p>
<p>Enlarged Holes</p> 	<p>Overloading</p>	<p>Replace chain and correct cause of overload</p>
<p>Cracked Plates (Corrosion Fatigue) Perpendicular to Pitch Line, plus rust or other evidence of chemical corrosion</p> 	<p>Corrosive environment</p>	<p>Replace chain and protect from hostile environment</p>
<p>Fractured Plates (Tension Mode)</p> 	<p>Overloading</p>	<p>Replace chain and correct cause of overload</p>
<p>Tight Joints</p> 	<p>Dirt or foreign substance packed in joints</p> <p>Corrosion and rust</p> <p>Bent pins</p>	<p>Clean and relube</p> <p>Replace chain and protect from hostile environment</p> <p>Replace chain</p>

Safety Precautions

1. Always wear safety goggles to protect eyes.
2. Select the right tool for the job.
3. Keep tools in good condition.
4. Use tools correctly.
5. Keep tools in a safe place.
6. Wear protective clothing, gloves and safety shoes as appropriate.
7. Use lengths of assembled chain. Do not build lengths from individual components.
8. Do not attempt to rework damaged chain by replacing only the components obviously faulty. The entire chain may be compromised and should be discarded.
9. Never electroplate assembled leaf chains or components. Plating will result in failure from hydrogen embrittlement.
10. Do not weld any chain or component. Welding spatter should never be allowed to come into contact with chain or components.
11. Leaf chains are manufactured exclusively from heat-treated steels and therefore must not be annealed. If heating a chain with a cutting torch is absolutely necessary for removal, the chain should not be reused.
12. Inspect chains frequently and regularly for link plate cracking, pin turning, pin protrusion and corrosion.
13. Use only PETOL™ & TITAN™ replacement parts to ensure proper strength.

Tong Inspection

It is recommended that the tong be visually inspected on a daily basis for signs of damaged or worn components.

Semi-annually, inspect the following areas for wear and/or damage (See “Inspection Wear Limits” for maximum allowable wear):

- Jaw Pin
- Jaw Pin Hole in the Jaw, Handle, and Pawl
- Handle Pin
- Handle Pin Hole

Contact PETOL™ GEARENCH for all suspected damage and repair.

Inspection Wear Limits

The following table indicates limiting diameters on the components of the PETOL™ Pulldown Visetongs. When localized wear is beyond any one of the limits indicated, the component should be replaced.

Tong	Part Number	Description	Location	Limit Diameter (inches)
VTDA115H	HP292	Jaw Pin	Pin Body	1.230 (min)
	HP356	Handle Pin	Pin Body	1.230 (min)
	TVJ115H	Jaw	Jaw Pin Hole	1.270 (max)
	HU62	Handle Bushing	Jaw Pin Hole	1.270 (max)
	VTDH115H	Handle	Handle Pin Hole	1.270 (max)
	TVP115	Pawl	Jaw Pin Hole	1.270 (max)
VTDA116H	HP277	Jaw Pin	Pin Body	1.725 (min)
	HP336	Handle Pin	Pin Body	1.355 (min)
	TVJ116H	Jaw	Jaw Pin Hole	1.775 (max)
	VTDH116H	Handle	Jaw Pin Hole	1.775 (max)
	VTDH116H	Handle	Handle Pin Hole	1.395 (max)
	TVP116HV	Pawl	Jaw Pin Hole	1.775 (max)
VTDA118	HP294	Jaw Pin	Pin Body	2.215 (min)
	HP276	Handle Pin	Pin Body	1.725 (min)
	TVJ118	Jaw	Jaw Pin Hole	2.285 (max)
	VTDH118	Handle	Jaw Pin Hole	2.285 (max)
	VTDH118	Handle	Handle Pin Hole	1.775 (max)
	TVP118	Pawl	Jaw Pin Hole	2.285 (max)
VTDA120	HP345	Jaw Pin	Pin Body	2.965 (min)
	HP222	Handle Pin	Pin Body	2.215 (min)
	TVJ120	Jaw	Jaw Pin Hole	3.040 (max)
	VTDH120	Handle	Jaw Pin Hole	3.040 (max)
	VTDH120	Handle	Handle Pin Hole	2.285 (max)
	TVP120	Pawl	Jaw Pin Hole	3.040 (max)

Safety Precautions

1. Always wear safety goggles to protect eyes.
2. Select the right tool for the job.
3. Keep tools in good condition.
4. Use tools correctly.
5. Keep tools in a safe place.
6. Wear protective clothing, gloves and safety shoes as appropriate.
7. Use lengths of assembled chain. Do not build lengths from individual components.
8. Do not attempt to rework damaged chain by replacing only the components obviously faulty. The entire chain may be compromised and should be discarded.
9. Never electroplate assembled leaf chains or components. Plating will result in failure from hydrogen embrittlement.
10. Do not weld any chain or component. Welding spatter should never be allowed to come into contact with chain or components.
11. Leaf chains are manufactured exclusively from heat-treated steels and therefore must not be annealed. If heating a chain with a cutting torch is absolutely necessary for removal, the chain should not be reused.
12. Inspect chains frequently and regularly for link plate cracking, pin turning, pin protrusion, and corrosion.
13. Use only PETOL™ & TITAN™ replacement parts to ensure proper strength.

Operation

The typical application of one PETOL™ Pulldown Visetong is shown in the figure below. Normally a vise is used as a backup. The vise is not shown for clarity. The tong will exert torque in the direction shown. The tong will ratchet when moved in a direction opposite to the line pull. Ratcheting is used when the tong must be pulled more than once to completely makeup or breakout the connection.

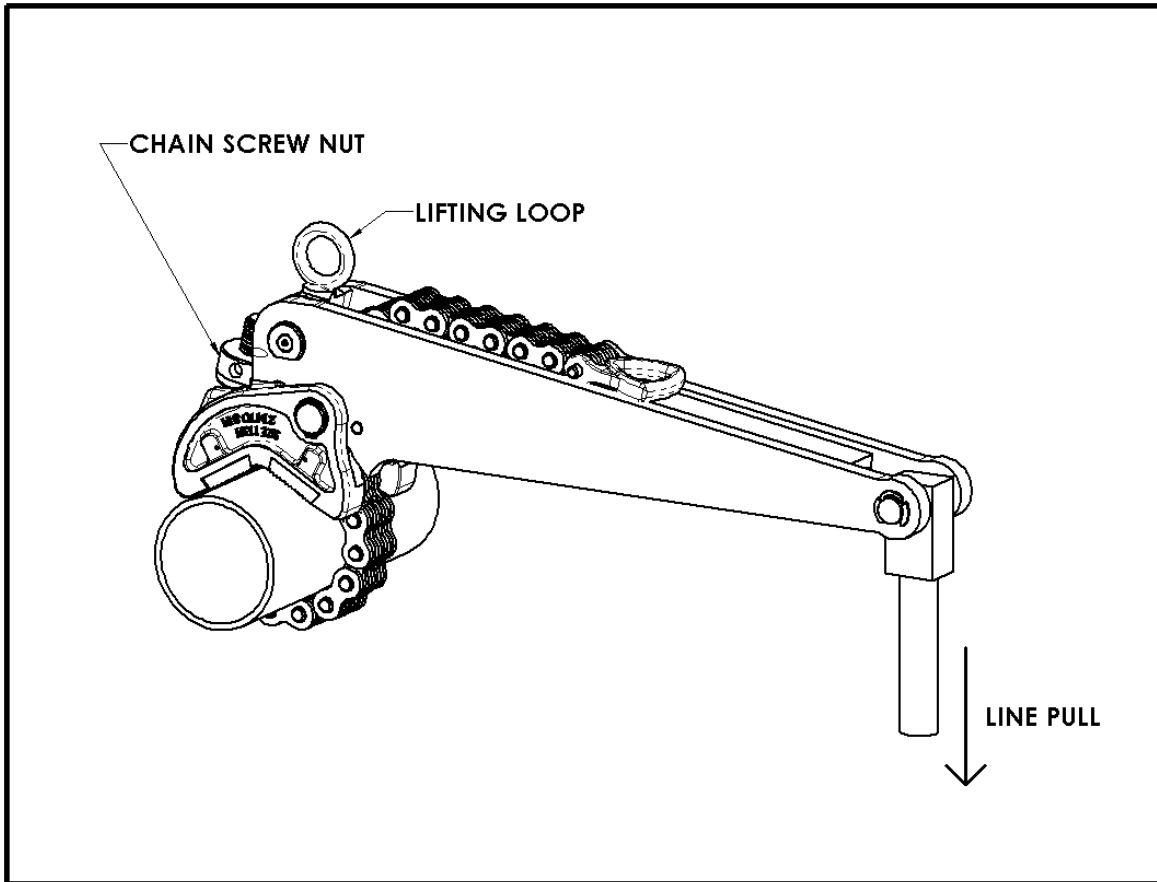

Pawl Operation

The following figure shows the Pawl and the Pawl Latch in their chain release (left) and chain lock (right) positions. Squeeze the Pawl Latch to the Pawl and rotate in the directions shown to set the Pawl in those positions. Loosen and tighten the chain while in the release position. Set the Pawl in the lock position when the chain is the proper length for the workpiece outer diameter. Operate the tong for making up or breaking out connections while in the lock position.

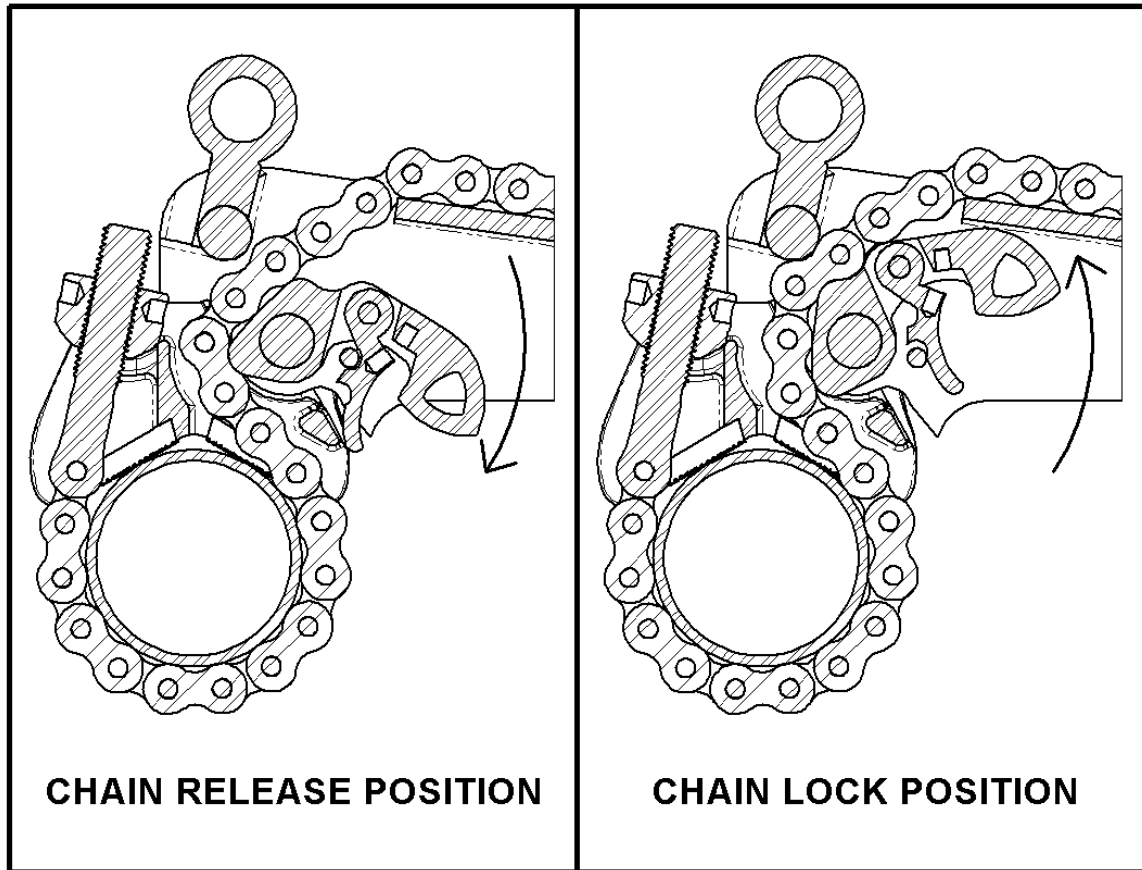

Torque Capacity

The maximum working torques and their corresponding handle loads, the outer diameter ranges, the gripping widths, and the torque arm lengths for the PETOL™ Pulldown Visetongs are shown in the table below.

Tong	Diameter Range (inches)	Gripping Width (inches)	Torque Arm Length (inches)	Maximum Torque (foot-pounds)	Maximum Line Pull (pounds)
VTDA115H	2 – 8	5.25	27.00	14,000	6,220
VTDA116H	4 – 14	7.25	39.38	50,000	15,230
VTDA118	4 – 24	9.00	50.00	90,000	21,600
VTDA120	6 – 24	12.63	41.00	200,000	58,530

WARNING: Under no circumstances should the maximum working load be exceeded. Always use a load cell or other calibrated indicating device to monitor the line pull on the tong to avoid an overload.

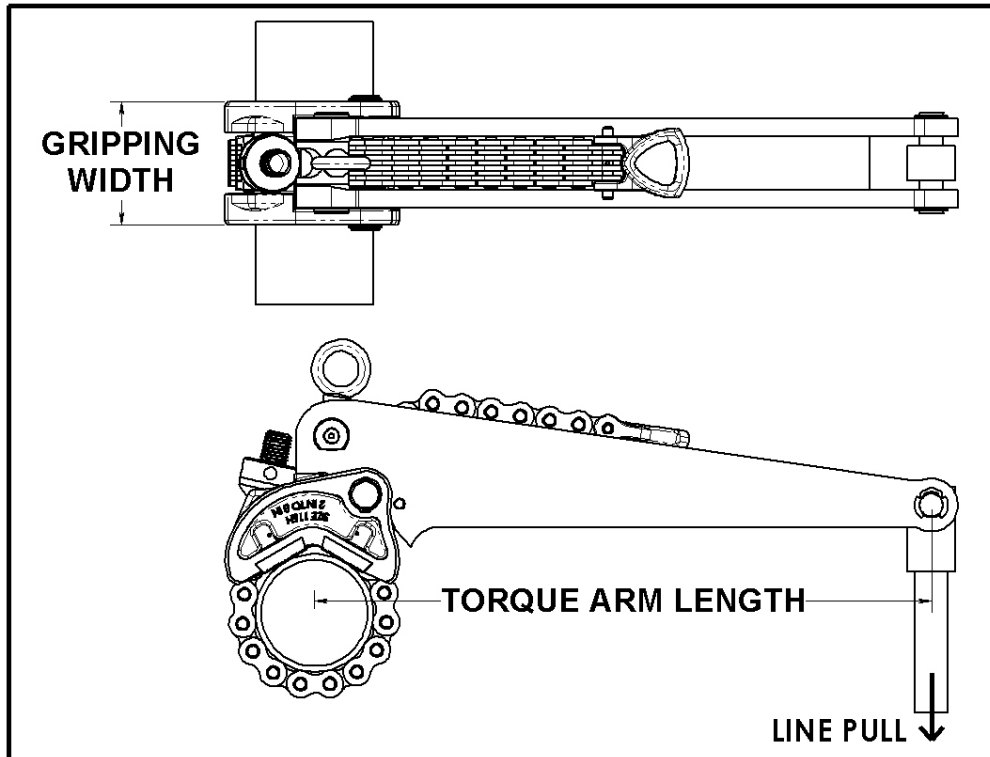

Parts Lists

The following drawings, diagrams, and parts lists describe all parts, which may be needed as replacement items.

**All tong components are manufactured only by PETOL™ GEARENCH .
DO NOT ATTEMPT TO SUBSTITUTE THESE COMPONENTS. The
tong will not work properly unless these components are matched to the
specific application. Consult our factory as your requirements change.
Any non- PETOL™ GEARENCH substitutions of these components void
all warranties and subject the user to assumption of liabilities resulting
from subsequent use.**

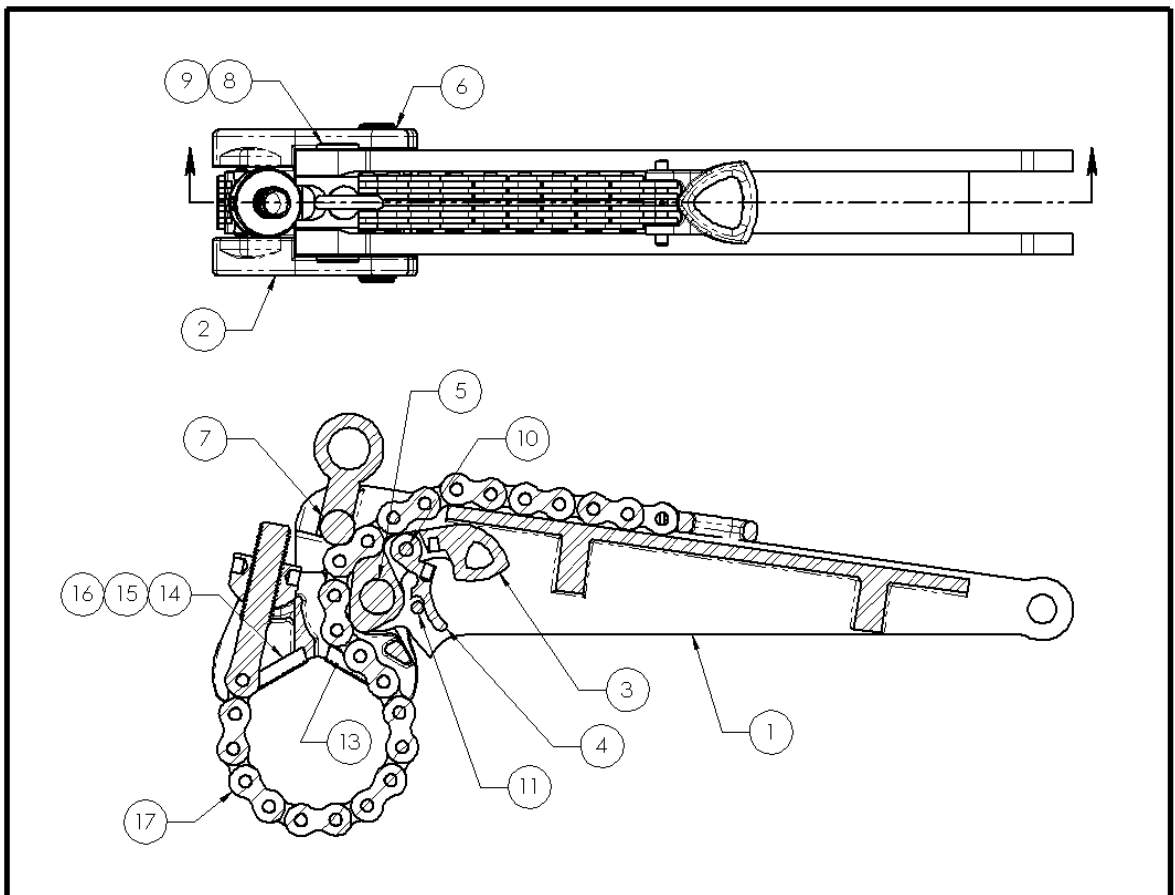

VTDA115H Parts List

Item	Qty.	Part Number	Description
1	1	VTDH115H	Handle
2	1	TVJ115H	Jaw
3	1	TVP115	Pawl
4	1	TVL116	Pawl Latch
5	1	HP292	Jaw Pin
6	2	HXRR125	Retaining Ring
7	1	HP356	Handle Pin
8	2	HP274-RP	Retaining Plate
9	2	HXS090	Retaining Plate Screw
10	1	HP026	Pawl Rivet
11	1	HP297	Pawl Latch Pin
12	1	HS25	Pawl Spring (not shown)
13	2	HI04D	Diamond Point Insert (STD)
13	2	HI04K	Knurled Insert (OPT)
14	2	HI04B	Blank Insert (STD)
14	2	HI04D	Diamond Point Insert (OPT)
14	2	HI04K	Knurled Insert (OPT)
15	4	HP903	Insert Key
16	4	HS20S	Insert Key Spring
17	1	See Table	Chain Assembly

VTDA116H Parts List

Item	Qty.	Part Number	Description
1	1	VTDH116H	Handle
2	1	TVJ116H	Jaw
3	1	TVP116HV	Pawl
4	1	TVL116HV	Pawl Latch
5	1	HP277	Jaw Pin
6	2	HXRR175	Retaining Ring
7	1	HP336	Handle Pin
8	2	HP275-RP	Retaining Plate
9	2	HXS090	Retaining Plate Screw
10	1	HP050	Pawl Rivet
11	1	HP298	Pawl Latch Pin
12	1	HS25	Pawl Spring (not shown)
13	2	HI09D	Diamond Point Insert (STD)
13	2	HI09K	Knurled Insert (OPT)
14	2	HI09B	Blank Insert (STD)
14	2	HI09D	Diamond Point Insert (OPT)
14	2	HI09K	Knurled Insert (OPT)
15	4	HP904	Insert Key
16	4	HS21	Insert Key Spring
17	1	See Table	Chain Assembly

VTDA118 Parts List

Item	Qty.	Part Number	Description
1	1	VTDH118	Handle
2	1	TVJ118	Jaw
3	1	TVP118V	Pawl
4	1	TVL118V	Pawl Latch
5	1	HP294	Jaw Pin
6	2	HXRR225	Retaining Ring
7	1	HP276	Handle Pin
8	2	HP276-RP	Retaining Plate
9	2	HXS090	Retaining Plate Screw
10	1	HP327	Pawl Pin
11	1	HP300	Pawl Latch Pin
12	1	HS01	Pawl Spring (not shown)
13	2	HI10D	Diamond Point Insert (STD)
14	2	HI10B	Blank Insert (STD)
14	2	HI10D	Diamond Point Insert (OPT)
15	4	HP904	Insert Key
16	4	HS21	Insert Key Spring
17	1	See Table	Chain Assembly
18	2	HXKR075	Pawl Pin Retainer (not shown)

VTDA120 Parts List

Item	Qty.	Part Number	Description
1	1	VTDH120	Handle
2	1	TVJ120	Jaw
3	1	TVP120	Pawl
4	1	TVL120	Pawl Latch
5	1	HP345	Jaw Pin
6	2	HXRR300	Retaining Ring
7	1	HP222	Handle Pin
8	2	HP279-RP	Retaining Plate
9	2	HXS090	Retaining Plate Screw
10	1	HP029	Pawl Pin
11	1	HP344	Pawl Latch Pin
12	1	HS03	Pawl Spring (not shown)
13	2	HI04D	Diamond Point Insert (STD)
14	2	HI04B	Blank Insert (STD)
14	2	HI04D	Diamond Point Insert (OPT)
15	4	HP904	Insert Key
16	4	HS21	Insert Key Spring
17	1	See Table	Chain Assembly
18	2	HXKR100	Pawl Pin Retainer (not shown)

Chain Assembly Parts Lists

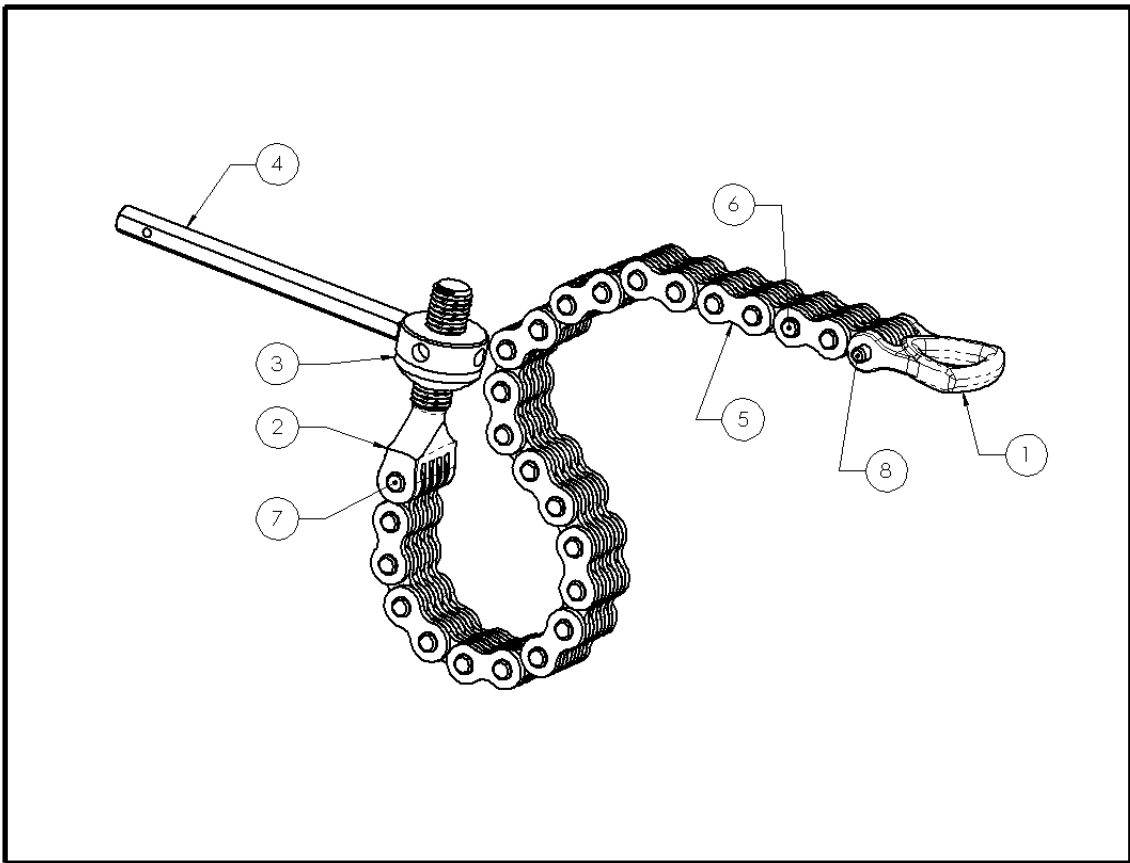

Chain Assemblies

Tong	Item	Part Number	Description
VTDA115H	1	HD2-45	Chain Handle
	2	HV07-45	Chain Screw
	3	HN05	Chain Screw Nut
	4	HP951	Nut Lever
	5	15-1-A	Chain Link
	6	HP034	Chain Rivet
	7	HP236	Chain Screw Rivet
	8	HP280	Chain Handle Pin
	9	HXC002	Cotter Pin (not shown)
VTDA116H	1	HD3-45	Chain Handle
	2	HV04-45	Chain Screw
	3	HN02	Chain Screw Nut
	4	HP952	Nut Lever
	5	16-1-A	Chain Link
	6	HP326	Chain Pin
	7	HP290	Chain Screw Rivet
	8	HP282	Chain Handle Pin
	9	HXC003	Cotter Pin (not shown)
	10	HXKR062	Retaining Ring (not shown)
VTDA118	1	HD4-45	Chain Handle
	2	HV05-45	Chain Screw
	3	HN03	Chain Screw Nut
	4	HP954	Nut Lever
	5	18-1-A	Chain Link
	6	HP327	Chain Pin
	10	HXKR075	Retaining Ring (not shown)
VTDA120	1	HD5-56	Chain Handle
	2	HV06-56	Chain Screw
	3	HN07	Chain Screw Nut
	4	HP955	Nut Lever
	5	20-1-A	Chain Link
	6	HP328	Chain Pin
	10	HXKR100	Retaining Ring (not shown)
	11	HB66	Lifting Eye (not shown)

Chain Selection

The following table lists typical chain assemblies used with these tongs and their outer diameter ranges.

Tong	Chain	Diameter Range (inches)
VTDA115H	151-45-25T	2 – 8
VTDA116H	161-45-25T	4 – 10
	161-45-33T	4 – 14
VTDA118	181-45-25T	4 – 12
	181-45-33T	4 – 18
	181-45-41T	4 – 24
VTDA120	201-56-19T	6 – 14
	201-56-25T	6 – 18
	201-56-31T	6 – 24