

# **PETOL™ Friction Breakout Unit**

## **ZB1260U**

### **Operating Manual**

**GEARENCH™**  
**P.O. Box 192**  
**4450 Highway 6 South**  
**Clifton, Texas 76634**  
**Phone: (254) 675-8651**  
**Fax: (254) 675-6100**

© 2016 by GEARENCH. All rights reserved

Form ZB1260U revision 10/21/16

## Table of Contents

<i>PETOL™ ZB1260U Unit Description</i> .....	3
<i>Warranty</i> .....	4
<i>Safe Practices and Procedures</i> .....	6
Responsibility.....	6
Replacement Parts .....	6
Safety .....	6
Safe Practices .....	7
Safety Sources and Publications.....	8
Responsibility of Distributors .....	8
<i>Installation</i> .....	10
Location .....	10
Setup .....	10
Recommended Equipment .....	10
<i>Operation</i> .....	11
Torque – Pressure Conversion Chart.....	11
Loading .....	12
Breaking Out .....	12
Making Up .....	12
Safe Operating Area .....	13
<i>Parts List</i> .....	14
Final Assembly Parts List .....	15
Cylinder Assembly .....	16

## **PETOL™ ZB1260U Unit Description**

The ZB1260U PETOL™ Friction Breakout Unit was designed for making up and breaking out downhole pumps and specialty downhole tools requiring accurate torque and no marking. The unit is equipped with a hydraulic cylinder, which may be powered by any hydraulic power source capable of producing up to 5000 psi.

The unit may be used with any pump shop equipment manufactured by GEARENCH™. The unit may be configured in any fashion using floor plates, pump stands, and extension stands for working on tools of any length.

### **Warning:**

**The unit should not be operated at a pressure above 5000 psi. The tong or wrench being used with the cylinder may have a torque rating lower than 5000 foot-pounds in which case the maximum operating pressure will be less. Applying too much pressure for the tong or wrench may result in damage to the tong or wrench and possibly in injury to personnel.**

## **Warranty**

### **What Is Covered**

GEARENCH™ tools are expressly warranted to you, the purchaser, to be free of defects in material and workmanship.

### **How Long Coverage Lasts**

This express warranty lasts for the lifetime of the GEARENCH tool. Warranty coverage ends when the tool becomes unusable for reasons other than defects in workmanship or material.

### **How Can You Get Warranty Service**

To obtain the benefit of this warranty, contact a GEARENCH sales representative in Clifton, Texas.  
GEARENCH · 4450 South Highway 6 · P.O. Box 192 · Clifton, TX 76634

### **What Will We Do To Correct Problems**

Warranted products will be repaired or replaced, at GEARENCH's option, and returned at no charge to you, the original purchaser; or, if after three attempts at repair or replacement during the warranty period, the product defect in material or workmanship persists, you can elect to receive a full refund of your original purchase price for the product.

### **What Is Not Covered**

Defects, failures or conditions that are due to normal wear and tear, abuse or misuse, are not covered by this limited warranty. In addition, this limited warranty is in lieu of all other warranties, express or implied, verbal or written. To the maximum extent allowed by law GEARENCH disclaims all implied warranties, including implied warranties of merchantability and/or fitness for a particular purpose. GEARENCH also specifically denies any liability for any incidental damages and/or consequential damages, including but not limited to property damage to property other than the product itself, loss of sales profits, down time, costs or any other damages measurable in money, whether or not included in the foregoing enumeration.

Please be advised that some states do not allow the exclusion or limitation of incidental or consequential damages, so this limitation or exclusion may not apply to you. This warranty gives you specific rights, and you may also have other rights, which vary from state to state, province to province, or country to country.

### **Are Personal Injuries Covered**

In the event you, someone working for you, or any other person sustain a personal injury as a result of using the GEARENCH tool, GEARENCH limits its potential liability for such a claim or injury to the fullest extent allowed by law, and disclaims and denies any liability for such personal injury.

Please be advised that some states do not allow the exclusion or limitation of liability for personal injuries, so the above limitation or exclusion may not apply to you, or the individual claiming injury.

### **No Other Express Warranty Applies**

This GEARENCH LIMITED WARRANTY is the sole and exclusive warranty, express or implied for GEARENCH products. No employee, agent, dealer or other person is authorized to alter, modify, expand or reduce the terms of this warranty or to make any other warranty on behalf of GEARENCH.

### **Law Applicable**

All matters related to the sale and/or use of the GEARENCH tool that is the subject of this limited warranty, along with the construction and enforcement of the terms of this limited warranty itself, shall be subject to the substantive and procedural laws of the state of Texas, not the conflicts of laws provisions of Texas, but rather the laws of Texas themselves.

**Forum Selection Clause**

Any dispute arising out of the sale and/or use of the GEARENCH tool that is the subject of this limited warranty shall be presented in the form of a claim or lawsuit to the offices of GEARENCH in Clifton, Bosque County, Texas. No claim or suit may be brought against GEARENCH, arising out of the sale and/or use of the tool, or arising out of the terms of this warranty, except in such forum. Purchase and/or use of the GEARENCH tool makes you subject to the benefits and limitations of this limited warranty. Accordingly, any writ, judgment or other enforcement, obtained from a jurisdiction, county, parish, state or federal court or other country, other than that from the forum identified above, shall be void and unenforceable against GEARENCH.

**Arbitration Clause**

In the event of dispute or claim arises out of the sale and/or use of the GEARENCH tool that is the subject of this limited warranty, or arises out of the interpretation or enforcement of the terms and conditions of this limited warranty, such dispute shall be submitted to binding arbitration pursuant to the rules of the American Arbitration Association. If required to accomplish the purpose of this Arbitration clause, the purchaser hereby expressly waives any right to demand trial by jury.

**Complete Agreement**

This express limited warranty contains the entire agreement regarding express or implied warranties related to the GEARENCH tool that is the subject of it. No writing or language contained in the purchase order or any other document of the purchaser, or invoice of GEARENCH or any intermediate seller, shall be construed as modifying, in any way, the rights and liabilities contained in this limited warranty. GEARENCH expressly disclaims any obligations expressed in any customer purchase order or document that are contrary to the terms and limitations of this warranty.

**Severability**

If any term or limitation contained in this limited warranty is deemed unenforceable by law, then the term shall be severed from the remaining portions of the limited warranty which shall remain enforceable.

All communications to GEARENCH regarding the use of the tool and any aspect of the sale of the tool of this limited warranty should be addressed to GEARENCH.

GEARENCH · 4450 South Highway 6 · P.O. Box 192 · Clifton, TX 76634

## **Safe Practices and Procedures**

### **Responsibility**

"It is the responsibility of the employer to train the employee in the proper selection and usage of tools, chains, etc., and to ensure that they are selected and used in that manner. In many instances, injury results because it is assumed that anybody knows how to use common hand tools. Observations and the record show that this is not the case. A part of every job instruction program should therefore be detailed training in the proper use of hand tools (and of all other special tools and equipment needed to accomplish the job)." - (Source: National Safety Council)

"Employers are responsible for the safe condition of tools and equipment used by employees, including tools and equipment which may be furnished by employees." - (Source: OSHA 1910.242A)

### **Replacement Parts**

Use only PETOL™ & TITAN™ replacement parts - no other parts are of comparable strength, quality and interchangeability.

### **Safety**

While we pride ourselves on the quality and dependability we build into GEARENCH™ tools and products, we caution users that it is only prudent to know and follow the simple rules of safety when using our products, or anyone else's.

Always follow safe practices and procedures in accordance with the recommendations of OSHA, The National Safety Council (NSC), The Hand Tools Institute (HTI), The National Association of Chain Manufacturers (NACM), The International Association of Drilling Contractors (IADC), Etc. All applicable Governmental rules, regulations or restrictions, now in effect or which may be promulgated, take precedence over the suggestions in this publication. The information in this publication is designed to supplement standard safe practices and procedures, not in lieu of, or replacement thereof.

## **Safe Practices**

**(Source: The National Safety Council)**

Failure to observe one or more of the following five safe practices accounts for most hand and powered tool accidents:

1. ALWAYS WEAR SAFETY GOGGLES TO PROTECT EYES
2. SELECT THE RIGHT TOOL FOR THE JOB
3. KEEP TOOLS IN GOOD CONDITION
4. USE TOOLS CORRECTLY
5. KEEP TOOLS IN A SAFE PLACE

Safety Goggles must always be worn by persons in any area where hand and powered tools are being used.

Never apply excess leverage to a wrench or tool by means of a "Cheater Bar". Never strike wrenches and tools with hammers or other objects.

All tools should be kept clean, inspected on a regular basis, and replaced when they show signs of wear.

Be especially careful not to place yourself in a position that could result in bodily injury in the event of a failure. Brace yourself firmly and pull rather than push when wrenching. (If necessary to push, do so with the flat of the hand rather than gripping around the wrench.)

Never stand under or near loads being hoisted off the ground.

**READ SAFE PRACTICES AND PROCEDURES MANUAL, CATALOG INFORMATION AND PRODUCT LABELING PRIOR TO OPERATION.**

Spinning and drill pipe chain, cathead chain, and the PETOL™ Connecting Link attachment are designed for the specific purpose for which the name indicates. Chains and attachments that are to be used for any other purpose should be selected in accordance with the recommendations of ASTM, NACM, Rigger's Handbook, and the commercial chain manufacturer's technical manuals.

## **Safety Sources and Publications**

In the interest of Safety the following sources of Safety information is furnished:

The Hand Tools Institute (HTI)  
25 North Broadway  
Tarrytown, New York 10591  
(914) 332-0040  
[www.hti.org](http://www.hti.org)

The National Safety Council (NSC)  
1121 Spring Lake Drive  
Itasca, Illinois 60143-3201  
(630) 285-1121  
[www.nsc.org](http://www.nsc.org)

International Safety Council  
1121 Spring Lake Drive  
Itasca, Illinois 60143-3201  
(630) 285-1121

## **Responsibility of Distributors**

IT IS THE RESPONSIBILITY OF THE PURCHASERS OF GEARENCH PRODUCTS TO CONVEY THE INFORMATION IN THIS PUBLICATION AND ANY OTHER INFORMATION RELATING TO THE INDIVIDUAL PRODUCT, THROUGH THE CHANNELS OF DISTRIBUTION, DOWN TO AND INCLUDING THE INDIVIDUAL USING THE PRODUCT

### **NOTE:**

**In view of the fact that the actual use determines whether safety requirements have been met, the ultimate responsibility to comply rests with the end user.**



## **Safety Precautions**

1. Always wear safety goggles to protect eyes.
2. Select the right tool for the job.
3. Keep tools in good condition.
4. Use tools correctly.
5. Keep tools in a safe place.
6. Wear protective clothing, gloves and safety shoes as appropriate.
7. Use only PETOL™ & TITAN™ replacement parts to ensure proper strength.

## **Installation**

### **Location**

The PETOL™ Friction Breakout Unit should be located in an area with adequate room to work the tools. The unit should be located indoors mounted on a finished shop floor. No special foundation is required.

### **Setup**

Locate the hydraulic power unit in a convenient location and connect the hoses to the hydraulic cylinder. Cycle the cylinder several times to clear the system of any entrapped air.

**Warning: Fully engage the quick connects with the hoses. The quick connects have leak prevention check valves. Failure to fully engage will result in over pressurization of the cylinder and cylinder failure.**

### **Recommended Equipment**

The following equipment is recommended for installation and operation. Only one pump is required. The recommended pumps are of minimum capacity. A larger or more elaborate pump or power unit may be used.

Installation kit	PETOL ZI1260-7
Hand pump	Enerpac P-84 Power Team P159-D
Electric pump (110V)	Enerpac WEM1304B Power Team PE104
Air pump	Enerpac PAM-1402N Power Team PA6D
Hoses (2 each)	Enerpac HC-913 (6 feet long)
Pressure gauge (See page 11)	PETOL UHCH-G06 (for Vickers TZ cylinder) PETOL UHCH-G09 (for all other cylinders)

## Operation

The hydraulic pressure gauge is used to indicate the current system pressure in psi. See the torque-pressure conversion chart below.

### **WARNING:**

**Never operate the tong with a pressure higher than required to perform the make up or break out operation. Operation at excessive pressure may damage the downhole tool and/or injure personnel.**

### **Torque – Pressure Conversion Chart**

The following chart is used on units with Vickers type TZ cylinders **ONLY**. The type is stamped on the rod end cylinder body. For all other cylinders, the pressure is equal to the torque (i.e.: 2000 psi = 2000 ft-lbs).

<b>PRESSURE - TORQUE CONVERSION</b>			
<b>Pressure</b>	<b>Torque</b>	<b>Pressure</b>	<b>Torque</b>
300	360	2300	2730
400	470	2400	2850
500	590	2500	2970
600	710	2600	3090
700	830	2700	3200
800	950	2800	3320
900	1070	2900	3440
1000	1190	3000	3560
1100	1310	3100	3680
1200	1420	3200	3800
1300	1540	3300	3920
1400	1660	3400	4030
1500	1780	3500	4150
1600	1900	3600	4270
1700	2020	3700	4390
1800	2140	3800	4510
1900	2250	3900	4630
2000	2370	4000	4750
2100	2490	4100	4870
2200	2610	4200	4980

## **Loading**

To load the tool in the unit set the tool into the vise or benchrench as needed. Adjust the vee-saddle or pump support to support the tool. Position the tong for make up or break out as needed and set the tong onto the tool. Attach the tong to the cylinder with the quick release pin.

### **CAUTION:**

**The vee-saddle or pump support must be used to support the tool while torquing.**

## **Breaking Out**

Load the tool and adjust the tong and vise as described above. Fully ratchet the tong. Slowly increase the system pressure until the connection is broken loose **or the working load of the tong is reached. Do not exceed the rating of the tong. Consult with GEARENCH™ as needed for help with the toughest break out jobs.** After the initial breakout, the tong may be unpinned from the cylinder and operated by hand until the connection is fully loosened.

## **Making Up**

Load the tool and adjust the tong and vise as described above. Make up the connection hand tight using the tong. Pin the tong to the cylinder. Fully extend the cylinder. Retract the cylinder increasing the pressure on the cylinder until the desired torque is reached.

## Safe Operating Area

For safe operation, it is recommended that the operator and other personnel not stand in the areas shown in the figure below during operation.

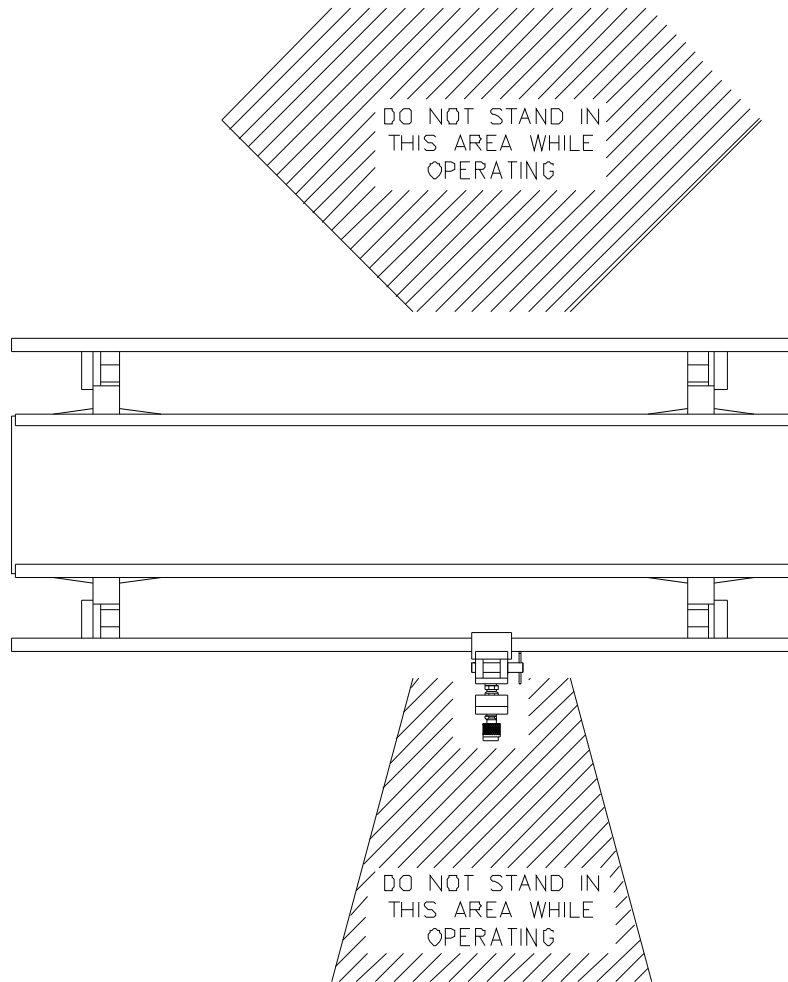

## **Parts List**

The following drawings, diagrams, and parts lists describe all parts, which may be needed as replacement items. Where appropriate, standard industrial and hydraulic components have been used. Should a standard industrial item need replacing, the item may be purchased locally. To assist you in obtaining parts, the OEM component manufacturer and model numbers are shown on the parts list. Of course, all replacement parts will be supplied by GEARENCH™ if you prefer to order from us.

**All tong, vise, and chain components are manufactured only by GEARENCH. DO NOT ATTEMPT TO SUBSTITUTE THESE COMPONENTS. The unit will not work properly unless these components are matched to the specific application. Consult our factory as your requirements change. Any non-GEARENCH substitutions of these components void all warranties and subject the user to assumption of liabilities resulting from subsequent use.**

## Final Assembly Parts List

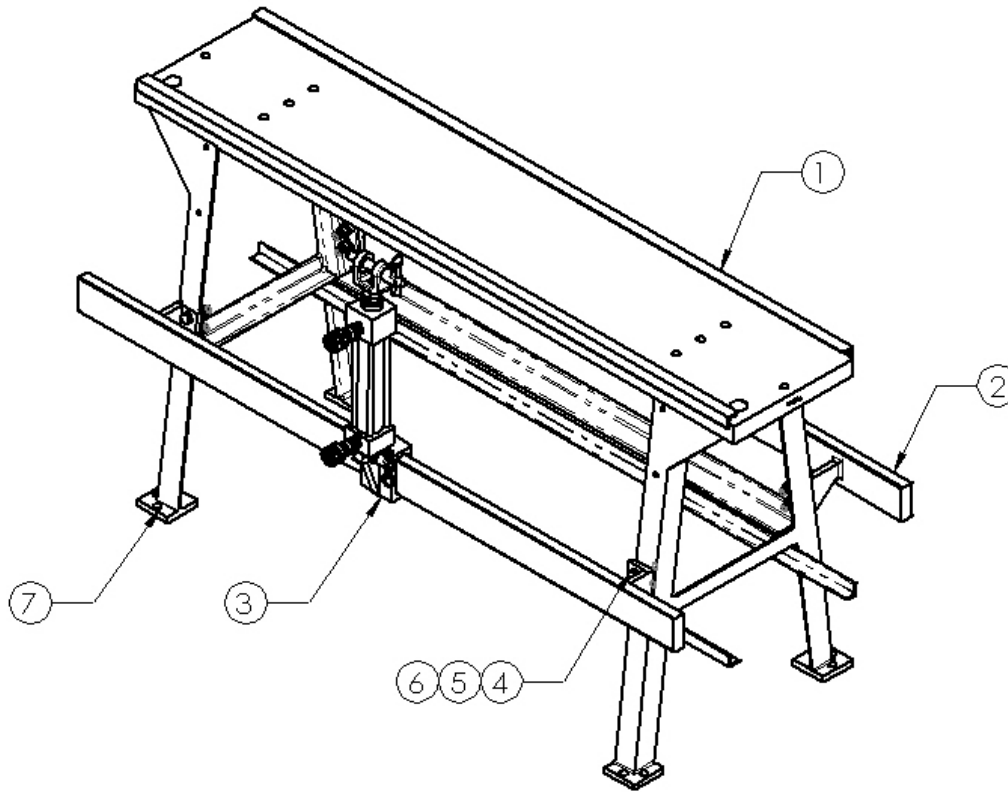

Item	Qty	Part Number	Description	Make/Model	Notes
1	1	ZB1260	Bench assembly		
2	1	ZB1260U-1	Rail		
3	1	UHCY-ZB	Cylinder assembly		See pages 13-14
4	8	HXS007	Hex bolt	½-13UNC x 1-3/4 Gr. 5	
5	8	HXN043	Hex nut	½-13UNC	
6	8	HXW005	Lock washer	½	
7	1	ZI1260-7	Installation kit		

## Cylinder Assembly

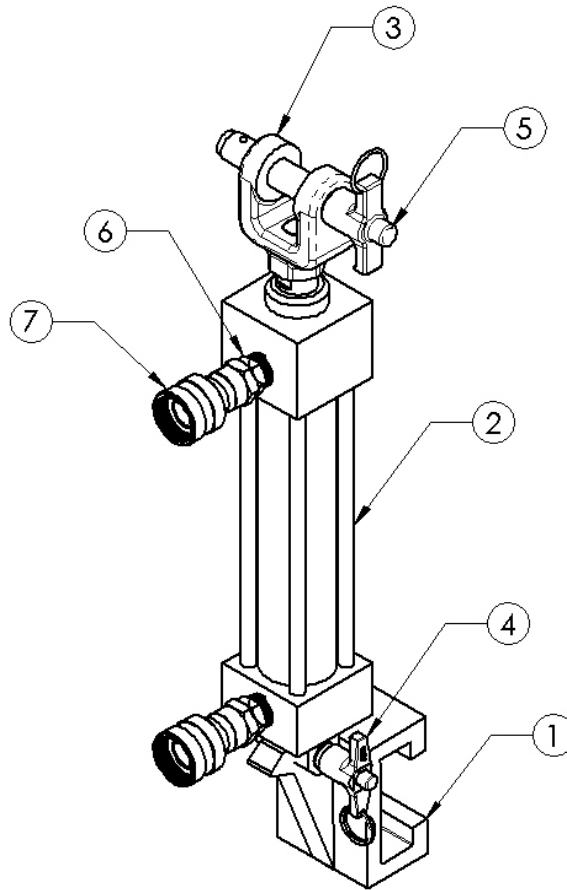

Item	Qty.	Part Number	Description	Make/Model	Notes
1	1	UHCY-ZB-EB	Eye bracket		
2	1	UHCY-ZB-C	Cylinder	Vickers/Aeroquip TG10CAGA1AA07000	
3	1	UHCY-ZB-RC	Rod clevis	Vickers/Aeroquip S-462-10	
4	1	HP374	Pin	McMaster-Carr 98325A498	Or equal
5	1	HP375	Pin	McMaster-Carr 98325A745	Or equal
6	2	UHCH-F45	Reducer bushing	Weatherhead C3109X8X6	Or equal
7	2	UHCH-Q05	Quick Connect	Enerpac CR-400	